

User's Guide



ADI-642

Multichannel Audio Digital Interface

SyncAlign[®]

SyncCheck[®]

Intelligent Clock Control[™]

SteadyClock[™]

Hi-Precision 24 Bit / 192 kHz
MADI - AES/EBU Interface
8-Channel / 64-Channel Format Converter
Analog 24 Bit / 192 kHz Stereo Monitor
72 x 74 Matrix Router
MIDI embedded in MADI
RS232 embedded in MADI

▶ **General**

1	Introduction	6
2	Package Contents	6
3	Brief Description and Characteristics	6
4	First Usage - Quick Start	
4.1	Controls and Connectors	7
4.2	Quick Start	8
5	Warranty	9
6	Appendix	9

▶ **Usage and Operation**

7	Front Panel Controls	
7.1	MADI INPUT	12
7.2	MADI OUTPUT	12
7.3	AES	12
7.4	CLOCK.....	13
7.5	REMOTE.....	14
7.6	MATRIX and ADC	14
7.7	MONITOR	16
8	Inputs	
8.1	MADI	16
8.2	AES/EBU.....	16
9	Outputs	
9.1	MADI	17
9.2	AES/EBU.....	17
10	Word Clock	
10.1	Word Clock Input and Output.....	18
10.2	Technical Description and Background	19
10.3	Cables and Termination.....	20
11	MIDI and RS232	
11.1	Transmission of MIDI	21
11.2	Remote Controlling the ADI-642	21
11.3	Remote Control Software.....	22
11.4	RS232	23
12	Application Examples	
12.1	Digital AES/EBU Breakout box	24
12.2	Digital AES/EBU Multicore	25
12.3	MADI to MADI Converter	27
12.4	AES Patchbay and Splitter.....	27
12.5	MADI Coax/Optical Converter.....	27
12.6	MADI Merger.....	27
12.7	MADInet	28

▶ **Technical Reference**

13	Technical Specifications	
13.1	Inputs	30
13.2	Outputs	30
13.3	MIDI – RS232	31
13.4	Digital	31
13.5	General	32
13.6	Firmware	32
13.7	Connector Pinouts	32
13.8	MADI User Bit Chart	32
14	Technical Background	
14.1	Terminology	33
14.2	Lock, SyncCheck and SyncAlign	34
14.3	AES/EBU – SPDIF	35
14.4	MADI Basics	36
14.5	SteadyClock	37
15	Block Diagram	38
16	MIDI Implementation Chart	
16.1	Basic SysEx Format	39
16.2	Message Types	39
16.3	MADI Input State – Redundancy Mode	39
16.4	Table	40

User's Guide



ADI-642

▶ General

1. Introduction

With the ADI-642 you have an incredibly versatile digital interface to your supply. What at first looks like a simple MADI/AES format converter, turns out to be a very flexible tool at a closer look. From small project studios to broadcast and television, this *Advanced Digital Interface* is the perfect solution for many tasks.

As a consequent continuation of RME's world-wide successful ADI series, the 642 also contains elaborate technology and the latest integrated circuits. In a few words: The ADI-642 is a uniquely powerful and high-quality device, which will excite you even after many years of operation.

2. Package Contents

Please check that your ADI-642 package contains each of the following:

- ADI-642
- Manual
- Power cord

3. Brief Description and Characteristics

The ADI-642 consists of two digital format converters in reference quality, in a standard 19" box with 1 unit height. The compact device has numerous extraordinary features like Intelligent Clock Control (ICC), SyncCheck[®], SyncAlign[®], SteadyClock, Auto Delay Compensation and patchbay functionality with 72x74 channel matrix router.

All of the ADI-642 I/Os support 192 kHz/24 bit. The format conversion between MADI and AES/EBU operates in both directions at the same time. LEDs of different colours show the present state of incoming and outgoing signals and of the internal processing in a clear way.

The unique Intelligent Clock Control (ICC) allows for a flexible use with internal clock (44.1 up to 192 kHz), external word clock or the digital input signals. These options are intelligently coupled in a way typical for RME, and easy to apply thanks to a clear and easily understandable display of the Lock and Sync states.

Furthermore the unique 72 x 74 Matrix Router allows to use the ADI-642 as digital patchbay, merger and splitter. All 72 input channels, MADI and AES, can be routed to all 74 outputs – even within the same format.

A special Auto Delay Compensation mode realizes a sample-accurate input and output signal of all AES/EBU I/Os, even when using multiple ADI-642s. The Auto Channel Assignment mode lets you configure the matrix of up to eight units with a single key stroke.

The ADI-642 transmits both MIDI and RS232 invisibly within the MADI data stream, maintaining full compatibility. The unit can also be remote controlled via MIDI.

4. First Usage – Quick Start

4.1 Controls and Connectors

The front of the ADI-642 features nine buttons, one rotary encoder, 38 LEDs and four seven segment displays, providing all necessary means for a detailed configuration of the unit.

MADI INPUT determines the current input for the MADI signal (optical/coaxial). Additionally, a detailed input state display analyses and presents the input signal status.



MADI OUTPUT is used to configure the MADI output as 56/64 channel or 48k/96k frame format.

AES INPUT STATE displays the presence of a valid input signal separately for each AES input. RME's exclusive *SyncCheck* indicates via flashing LEDs if one of these inputs is locked, but not synchronous to the others.

In the **CLOCK SECTION** the current clock reference and frequency multiplier is chosen. **REMOTE** defines the source for MIDI remote control operation (MADI or DIN jacks).



The **MATRIX** section is used to configure the routing of all inputs and outputs. Auto Delay Compensation (**ADC**) prevents offsets when using multiple ADI-642s.

The **MONITOR** section offers a 24 bit/192 kHz capable Line/phones output to monitor the input signals.

The rear of the ADI-642 provides all the connections: eight AES/EBU (XLR), two MADI optical, two MADI coaxial (BNC), two word clock (BNC), two MIDI (5-pin DIN), one RS232 (D-Sub), and mains power.

MADI I/O optical: Standard MADI ports.

MADI I/O coaxial (BNC): Standard MADI ports.

AES/EBU INPUTS (XLR): Transformer-coupled, high sensitivity, therefore accepts SPDIF signals as well.

AES/EBU OUTPUTS (XLR): Transformer-coupled, fully AES/EBU compatible.

WORD IN (BNC): A push switch allows to activate internal termination (75 Ohms).

WORD OUT (BNC): Standard word clock output.

IEC receptacle for power connection. The specially developed, internal hi-performance switch mode power supply makes the ADI-642 operate in the range of 100V to 240V AC. It is short-circuit-proof, has an integrated line-filter, is fully regulated against voltage fluctuations, and suppresses mains interference.

4.2 Quick Start

Configuration starts with choosing the MADi input, BNC or optical. The state of the input signal is displayed by 14 LEDs. Shown are active input, automatic input selection, receiver state, Sync, 56 or 64 channel format, 48k frame or 96k frame, and audio data within 8-channel groups. The Sync LED shows the synchronicity between input signal and external/internal clock, or between the active inputs.

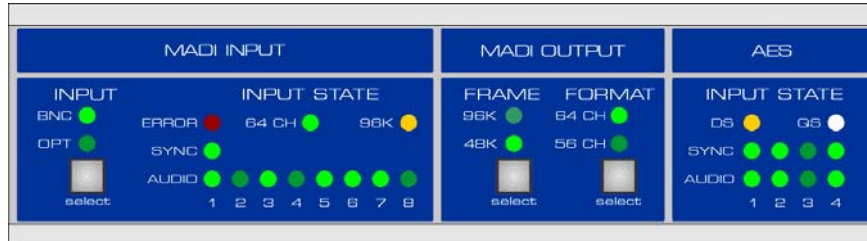

The MADi output signal can include 56 or 64 channels (FORMAT). The FRAME key switches the MADi output into native Double Speed mode (96K), in case internal or external clock allow this mode to be activated.

In the AES INPUT STATE section, each input has its own SYNC LED. One LED per (stereo) input signals audio information within the data stream. An AES/EBU or SPDIF signal in the range of 60 kHz to 100 kHz will turn the DS (Double Speed) LED on. An AES/EBU or SPDIF signal in the range of 162 kHz to 200 kHz will turn the QS (Quad Speed) LED on.

The source and frequency of the unit's clock is configured in the CLOCK SECTION. The button CLOCK lets you step through the options external clock (AES, MADi, word) and internal clock (44.1 or 48 kHz). The button STATE sets the range for the internal, but also the external sample rate. Selecting DS will result in 88.2 and 96 kHz, selecting QS sets 176.4 and 192 kHz.

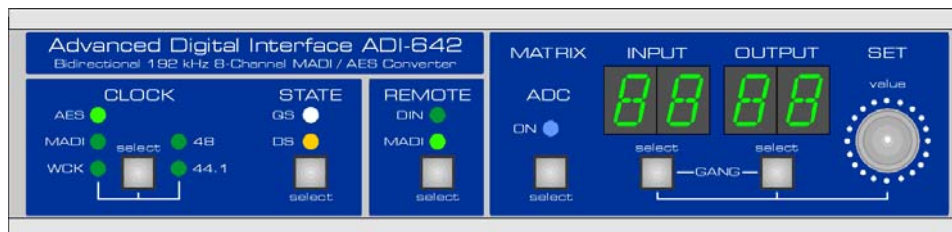

The ADI-642 can be remote controlled by MIDI commands. The button REMOTE is used to select the source of the MIDI remote control commands, and also the destination for the ADI-642's request replies. The standard MIDI ports or the MADi input and output can be chosen.

The matrix router is always active and allows to change the routing. First choose an output by pressing the OUTPUT select key, then use the INPUT select key to select the desired input. An input can be assigned to as many outputs as present (splitting), but an output can not be assigned to more than one input (digital mixing).

The button ADC activates the *Auto Delay Compensation*, which is very useful when using multiple ADI-642 in a serial connection setup. With activated ADC the *Auto Channel Assignment* mode is also available, see chapter 7.6.

The ADI-642 remembers all settings before switching off, and sets them automatically when switching on the next time. The storing process is triggered 4 seconds after the last change, and is signalled in the display as quickly moving point.

5. Warranty

Each individual ADI-642 undergoes comprehensive quality control and a complete test at IMM before shipping. The usage of high grade components allow us to offer a full two year warranty. We accept a copy of the sales receipt as valid warranty legitimation.

If you suspect that your product is faulty, please contact your local retailer. The warranty does not cover damage caused by improper installation or maltreatment - replacement or repair in such cases can only be carried out at the owner's expense.

Synthax Audio AG does not accept claims for damages of any kind, especially consequential damage. Liability is limited to the value of the ADI-642. The general terms of business drawn up by Synthax Audio AG apply at all times.

6. Appendix

RME news and further information can be found on our website:

<http://www.rme-audio.com>

Distributor: Synthax Audio AG, Am Pfanderling 62, D-85778 Haimhausen, Tel.: (49) 08133 / 91810

Manufacturer:

IMM Elektronik GmbH, Leipziger Strasse 32, D-09648 Mittweida

Trademarks

All trademarks and registered trademarks belong to their respective owners. RME, SyncAlign, Hammerfall and SyncCheck are registered trademarks of RME Intelligent Audio Solutions. ADI-642, SteadyClock, ADC and Intelligent Clock Control (ICC) are trademarks of RME Intelligent Audio Solutions. Alesis and ADAT are registered trademarks of Alesis Corp. TDIF is a trademark of Teac Corp. ADAT optical is a trademark of Alesis Corp. S/MUX is copyright Sonorus.

Copyright © Matthias Carstens, 1/2007. Version 1.3

All entries in this User's Guide have been thoroughly checked, however no guarantee for correctness can be given. RME cannot be held responsible for any misleading or incorrect information provided throughout this manual. Lending or copying any part or the complete manual or its contents as well as the software belonging to it is only possible with the written permission from RME. RME reserves the right to change specifications at any time without notice.

CE / FCC Compliance

CE

This device has been tested and found to comply with the limits of the European Council Directive on the approximation of the laws of the member states relating to electromagnetic compatibility according to RL89/336/EWG and RL73/23/EWG.

FCC Compliance Statement

Certified to comply with the limits for a Class B computing device according to subpart J or part 15 of FCC rules. See instructions if interference to radio reception is suspected.

FCC Warning

This equipment has been tested and found to comply with the limits for a Class B digital device, pursuant to part 15 of the FCC rules. These limits are designed to provide reasonable protection against harmful interference in a residential installation.

This device complies with part 15 of FCC rules. Operation is subject to the following two conditions:

1. This device may not cause harmful interference
2. This device must accept any interference received, including interference that may cause undesired operation.

However, there is no guarantee that interference will not occur in a particular installation. If this equipment does cause harmful interference to radio or television reception, which can be determined by turning the equipment off and on, the user is encouraged to try to correct the interference by one or more of the following measures:

- Reorient or relocate the receiving antenna
- Increase the separation between the equipment and receiver
- Connect the equipment into an outlet on a circuit different from that to which the receiver is connected
- Consult the dealer or an experienced radio/TV technician for help.

In order for an installation of this product to maintain compliance with the limits for a Class B device, shielded cables must be used for the connection of any devices external to this product.

Note on Disposal

According to the guide line RL2002/96/EG (WEEE – Directive on Waste Electrical and Electronic Equipment), valid for all European countries, this product has to be recycled at the end of its lifetime.

In case a disposal of electronic waste is not possible, the recycling can also be done by IMM Elektronik GmbH, the manufacturer of the Micstasy.



For this the device has to be sent **free to the door** to:

IMM Elektronik GmbH
Leipziger Straße 32
D-09648 Mittweida
Germany

Shipments not prepaid will be rejected and returned on the original sender's costs.

User's Guide



ADI-642

▶ Usage and Operation

7. Front panel Controls

7.1 MADI INPUT

The button INPUT sets the input to optical or coaxial. The section INPUT STATE helps to avoid errors caused by wrong, missing or not correctly connected inputs, and makes handling the digital MADI format much easier. A total of 14 LEDs display the state of the current input signal.

The SYNC LED lights up as soon as a valid signal is present at the input. An un-synchronous input signal will be signalled by flashing of the SYNC LED. A missing or invalid input signal will cause the ERROR LED to light up.

Audio data present in the input channels is signalled by one AUDIO LED per 8-channel block. The green LED is lit as soon as one of the channels of an 8-channel block contains audio data, that is no longer digital zero.

64-channel and 96k frame format are displayed by one LED each. With those LEDs off, the input signal is 56-channel and 48k frame format.

7.2 MADI OUTPUT

The buttons FRAME and FORMAT configure the MADI output signal as follows:

FRAME: 48k or 96k frame. 48k frame can be used with Single, Double and Quad Speed. 96k frame is limited to the range 64 kHz to 96 kHz (Double Speed).

FORMAT: 56-channel or 64-channel format.

7.3 AES

The INPUT STATE of the four inputs is displayed by 10 LEDs.

Each input has its own SYNC LED. If a valid input signal is applied, SyncCheck is active automatically. SyncCheck takes the chosen clock (internal, external, etc.) as reference and compares it with the input clocks. Inputs which are not synchronous will be signalled by flashing of the corresponding SYNC LED.

An AES/EBU or SPDIF signal in the range of 60 kHz to 100 kHz will turn the DS (Double Speed) LED on. An AES/EBU or SPDIF signal in the range of 162 kHz to 200 kHz will turn the QS (Quad Speed) LED on.

The LEVEL LED lights up as soon as the digital signal carries an information other than digital zero. The channel doesn't matter. So there is only one channel of audio information necessary for the LED to light up. The amount of level is not indicated.

7.4 CLOCK

The source and frequency of the unit's clock is configured in the CLOCK SECTION. The button CLOCK lets you step through the options external clock (AES, MADI, word) and internal clock (44.1 or 48 kHz). The button STATE sets internal, but also the external sample rate to double or quadruple of the basic sample rate.

AES, MADI, WCK (Slave Mode)

Defines the corresponding input as clock reference. A missing or invalid clock source signal is indicated by flashing of the corresponding LED. In case of AES: the input with the lowest number receiving a valid AES signal is used as clock reference.

44.1, 48 (Master Mode)

Activates the internal clock at 44.1 kHz or 48 kHz. Using the button STATE a choice of DS gives 88.2 and 96 kHz, a choice of QS gives 176.4 and 192 kHz respectively.



With a setting of 44.1 and 48 (internal clock) it is mandatory that the clock rate of the sources is synchronous to the ADI-642. Therefore the external device has to be synchronized to the ADI-642's word clock out or MADI/AES out.

The ADI-642 thus has to be master, all devices connected to it slave. In order to avoid clicks and drop outs due to faulty or missing synchronicity, a special process called *SyncCheck* compares the incoming data and the ADI-642's internal clock. The SYNC state is indicated by a flashing (error) or constantly lit (OK) LED.

The button STATE is used to configure the ADI-642, and with this all of its outputs, to the frequency ranges Single Speed, Double Speed or Quad Speed.

Single Speed (no LED)

All outputs carry a signal in the range of 32 kHz up to 48 kHz.

Double Speed (LED DS)

All AES outputs carry a signal in the range of 64 kHz up to 96 kHz. MADI stays at no higher than 48 kHz, with the data transmitted in the S/MUX format. In case MADI OUTPUT has been set to 96k frame, the MADI output also uses 96 kHz.

Quad Speed (LED QS)

All AES outputs carry a signal in the range of 176.4 kHz up to 192 kHz. MADI stays at no higher than 48 kHz, with the data transmitted in the S/MUX4 format. Using the 96k frame mode with S/MUX data transmission is not supported.

Follow Clock

In this special mode the ADI-642 follows the input clock of AES and Word automatically over all three ranges. So at 96 kHz the DS LED automatically lights up, at 192 kHz the QS LED. A manual configuration via the STATE button is no longer required. This function is deactivated for the MADI input, as the sample rate range of the MADI audio data can not be detected automatically.

Activation of Follow Clock: while the firmware version is shown press the CLOCK STATE button. Both LEDs DS/QS light up. Deactivation: same, both LEDs stay dark.

7.5 REMOTE

The button REMOTE is used to select the source of the MIDI remote control commands, and also the destination for the ADI-642's request replies. The standard MIDI ports or the MADI input and output can be chosen.

In order to remote control multiple ADI-642 that are connected in a serial way, without the need of using an external MIDI splitter and merger, the ADI-642 passes on all MIDI data from the MADI input to the MADI output. This way no further external cabling is necessary. However, as all the received MIDI data are sent back immediately, a MIDI loop (feedback) may occur. In such a case at least the last unit of a serial chain should not be set to REMOTE MADI.

The remote control software *MIDI Remote* will not cause any MIDI feedback, because the software is especially designed for this kind of operation.

Note: Via MIDI remote control, all front panel controls can be locked (Lock Keys). An exception is the REMOTE key. In Off-state Lock Keys is deactivated. Therefore a locking of all the controls can be revoked directly at the unit at any time.

7.6 MATRIX and ADC

The MATRIX section includes means to control the channel assignment of inputs and outputs, and for the offset compensation when using multiple ADI-642.

Matrix

With both buttons INPUT and OUTPUT the matrix offers access to all 64 MADI channels and all 8 AES channels. Therefore the AES I/Os can be connected freely to the MADI I/Os. With this, format independent routing, splitting and inserting is possible with any single channel.



An input channel can be assigned to as many output channels as available (splitting), but an output can not be assigned to more than one input (digital mixing).

Setting up the routing on a per-channel basis is done in two steps:

- Push and hold the OUTPUT button. Select the desired output channel by turning the SET knob (rotary encoder)
- Push and hold the INPUT button. Select the desired input channel by turning the SET knob (rotary encoder)

Ganging: Press and hold both buttons, then turn the SET button. Input and Output will change simultaneously.

Empty Input display: Equals mute. The corresponding output will not receive any input signal.

Horizontal lines: No valid selection. Example: the display shows 64/64, then the unit is switched into Double Speed mode. Now these channels no longer exist (32 channels maximum in DS operation).

Monitor: The phones output is shown in the display as *Ph*. It can be assigned to any of the inputs, but always uses the next input channel too. So when selecting 02 the MADI channel 2 is sent to the left output, MADI channel 3 will be sent to the right output.

ADC

The *Auto Delay Compensation* realizes an offset compensation when using multiple ADI-642 connected serially (see chapter 12). For this, ADC is activated at the first unit of the chain, turning the unit into the *ADC Master*. The blue LED lights up bright. Immediately the blue LEDs of all other units light up less bright automatically. These units are now *ADC Slaves**. The display shows an information about the unit's current position within the chain (*id 02* or higher).

If the button ADC is pushed at any of the ADC Slaves, the corresponding unit will become a Master as well, and the chain gets divided.

Additionally the rotary encoder of the first ADI-642 (the ADC Master) can be used to activate the *Auto Channel Assignment*, which sets up the AES I/Os of all units automatically in a logical order. For this push and hold the OUTPUT button, then use the rotary encoder to select *Auto* (appears on the display between Ph and 01). This display will also appear on the other ADI-642s, together with the corresponding ID (*Au 02* or higher). The former matrix configuration is not lost, and will become active again immediately when switching off the Auto Channel mode.



In Auto Channel mode the channel assignment is fixed and can not be changed. Therefore the buttons INPUT, OUTPUT and SET are locked on all ADC Slave units. The routing is as follows:

Unit 1:

AES In 1-8 to MADI Out 1-8

MADI In 1-8 to AES Out 1-8

MADI In 9-64 to MADI Out 9-64.

Unit 2:

AES In 1-8 to MADI Out 9-16

MADI In 9-16 to AES Out 1-8

MADI In 1-8 and 17-64 to MADI Out 1-8 and 17-64

Unit 3:

AES In 1-8 to MADI Out 17-24

MADI In 17-24 to AES Out 1-8

MADI In 1-16 and 25-64 to MADI Out 1-16 and 25-64

Unit 4:

AES In 1-8 to MADI Out 25-32

MADI In 25-32 to AES Out 1-8

MADI In 1-24 and 33-64 to MADI Out 1-24 and 33-64

Etc.

AES 1-8 of the second unit represents AES channels 9-16, third unit AES 17-24 and so on.

Note: The activation of the ADC mode also activates the pass-through of the serial RS232 input data from the ADC Master via all ADC Slaves to the next ADC Master. See chapter 11.4.



* The ADI-642 uses the user bit of channel 19 to transmit the ADC and Auto Channel state to other devices.

7.7 MONITOR

The 192 kHz capable stereo monitor output can be used to monitor any of the input channels. Setup is done by selecting OUTPUT Ph in the matrix section. Ph can be assigned to any of the input channels, but always uses the next input channel as well. So when selecting 02 the MADI channel 2 is sent to the left output, MADI channel 3 will be sent to the right output.

The low impedance driver stage is capable of driving headphones. The output level can be adjusted manually via the VOL pot.

Note: The current Ph channel assignment stays active even when activating ADC Auto Channel Assignment mode.

8. Inputs

8.1 MADI

Both MADI inputs are located on the rear of the ADI-642.

The BNC input's ground-free design is built according to AES10-1991. The input's impedance is 75 Ohm. It will operate without error from about 180 mVpp.

The optical input uses a FDDI (ISO/IEC 9413-3) compatible optical module, according to AES10-1991. More information can be found in chapter 14.4, MADI Basics.

The ADI-642 includes automatic input selection. In case the current input signal fails, the unit switches to the other input immediately. This mode, called redundancy mode, offers improved safety against errors on the transmission line. Switching the inputs is done in about one second. The ADI-642 displays redundancy operation by a blinking LED of the original input, while the input LED of the currently active input will be lit constantly.

8.2 AES/EBU

At the rear side of the ADI-642 there are four XLR sockets for the AES/EBU inputs. All inputs are transformer-balanced and ground-free. Channel status and copy protection are being ignored.

Thanks to a highly sensitive input stage, SPDIF signals can also be processed by using a simple cable adapter phono/XLR. To achieve this, pins 2 and 3 of a male XLR plug are connected individually to the two pins of a phono plug. The cable shielding is only connected to pin 1 of the XLR - not to the phono plug.

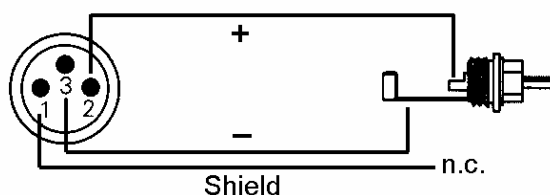

The inputs can be used in any combination, e. g. it is sufficient to connect an input signal only to input 3. In slave mode, this input is automatically being used as clock source. If more than one signal is present, the one furthest left is being used as clock source, i. e. the active input with the lowest number.

The ADI-642 supports single wire only, in the range of 32 kHz up to 192 kHz: a total of 8 channels, 2 channels per AES wire. The effective sample frequency equals the clock on the AES wire. In case a conversion from/to Single, Double and Quad Wire is required, the ADI-192 DD, an 8-channel universal sample rate and format converter, is highly recommended.

Emphasis

AES/EBU and SPDIF can contain an Emphasis information. Audio signals with Emphasis have a strong high frequency boost and thus require a high frequency attenuation on playback.

 *An Emphasis indication gets lost! This information is neither passed on to the MADI output, nor to any of the AES outputs!*

9. Outputs

9.1 MADI

At the rear side of the ADI-642 there are two MADI outputs.

The BNC output is built according to AES10-1991. The output's impedance is 75 Ohm. The output voltage will be 600 mVpp when terminated with 75 Ohm.

The optical output uses a FDDI (ISO/IEC 9413-3) compatible optical module, according to AES10-1991. More information can be found in chapter 14.4, MADI Basics.

9.2 AES/EBU

At the rear side of the ADI-642 there are four XLR sockets as AES/EBU outputs. Each output is transformer-balanced, ground-free and compatible to all devices with AES/EBU ports. Connection is accomplished using balanced cables with XLR plugs.

Besides the audio data, digital signals in SPDIF or AES/EBU format contain a channel status coding, which is being used for transmitting further information. The output signal coding of the ADI-192 DD has been implemented according to AES3-1992 Amendment 4:

- 32 kHz, 44.1 kHz, 48 kHz, 64 kHz, 88.2 kHz, 96 kHz, 176.4 kHz, 192 kHz according to the current sample rate
- Audio use
- No Copyright, Copy permitted
- Format Professional
- Category General, Generation not indicated
- 2-Channel, No Emphasis
- Aux Bits Audio use, 24 Bit
- Origin: A642

Connecting devices with coaxial SPDIF ports to the ADI-642 is accomplished by a simple cable adapter XLR/phono. Pins 2 and 3 of a female XLR plug are connected individually to the two pins of a phono plug. The cable shielding is only connected to pin 1 of the XLR - not to the phono plug.

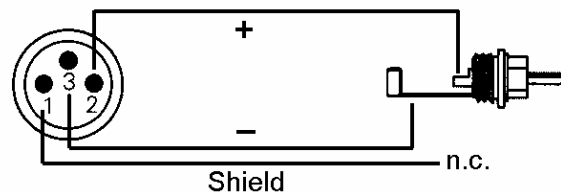

 *Note that most consumer HiFi equipment with phono SPDIF inputs will only accept signals having a Channel Status 'Consumer' format! In such cases the above adapter cable will therefore not work.*

10. Word Clock

10.1 Word Clock Input and Output

SteadyClock guarantees an excellent performance in all clock modes. Its highly efficient jitter suppression refreshes and cleans up any clock signal, and provides it as reference clock at the BNC output (see section 14.5).

Input

The ADI-642's transformer isolated word clock input is active when WCK is chosen in the clock section. The signal at the BNC input can be Single, Double or Quad Speed, the ADI-642 automatically adapts to it. As soon as a valid signal is detected, the WCK LED is constantly lit, otherwise it is flashing.

Thanks to RME's *Signal Adaptation Circuit*, the word clock input still works correctly even with heavily mis-shaped, dc-prone, too small or overshoot-prone signals. Thanks to automatic signal centering, 300 mV (0.3V) input level are sufficient in principle. An additional hysteresis reduces sensitivity to 1.0 V, so that over- and undershoots and high frequency disturbances don't cause a wrong trigger.

The ADI-642's word clock input is shipped as high impedance type (not terminated). A push switch allows to activate internal termination (75 Ohms). The switch is found on the back beside the BNC jacks. Use a small pencil or similar and carefully push the blue switch so that it snaps into its lock position. Another push will release it again and de-activate the termination.



Output

The word clock output is constantly active, providing the current sample frequency as word clock signal. In master mode, the word clock will be fixed to 44.1 kHz or 48 kHz (DS x 2, QS x 4). In any other case the sample rate is identical to the one present at the currently chosen clock input. When the current word clock source fails, the last valid sample rate will be held automatically.

The word clock signal received by the ADI-642 can be distributed to other devices by using the word clock output. With this the usual T-adapter can be avoided, and the ADI-642I operates as *Signal Refresher*. This kind of operation is highly recommended, because

- Input and output are phase-locked and in phase (0°) to each other
- *SteadyClock* removes nearly all jitter from the input signal
- the exceptional input (1 Vpp sensitivity instead of the usual 2.5 Vpp, dc cut, *Signal Adaptation Circuit*) plus *SteadyClock* guarantee a secure function also with most critical word clock signals.

Thanks to a low impedance, but short circuit proof output, the ADI-642 delivers 4 Vpp to 75 Ohms. For wrong termination with 2 x 75 Ohms (37.5 Ohms), there are still 3.3 Vpp at the output.

10.2 Operation and Technical Background

In the analog domain one can connect any device to another device, a synchronization is not necessary. Digital audio is different. It uses a clock, the sample frequency. The signal can only be processed and transmitted when all participating devices share the same clock. If not, the signal will suffer from wrong samples, distortion, crackle sounds and drop outs.

AES/EBU, SPDIF, ADAT and MADI are self-clocking, an additional word clock connection in principle isn't necessary. But when using more than one device simultaneously problems are likely to happen. For example any self-clocking will not work in a loop cabling, when there is no 'master' (main clock) inside the loop. Additionally the clock of all participating devices has to be synchronous. This is often impossible with devices limited to playback, for example CD players, as these have no SPDIF input, thus can't use the self clocking technique as clock reference.

In a digital studio synchronisation is maintained by connecting all devices to a central sync source. For example the mixing desk works as master and sends a reference signal, the word clock, to all other devices. Of course this will only work as long as all other devices are equipped with a word clock or sync input, thus being able to work as slave (some professional CD players indeed have a word clock input). Then all devices get the same clock and will work in every possible combination with each other.



Remember that a digital system can only have one master! If the ADI-642's uses its internal clock, all other devices must be set to 'Slave' mode.

But word clock is not only the 'great problem solver', it also has some disadvantages. The word clock is based on a fraction of the really needed clock. For example SPDIF: 44.1 kHz word clock (a simple square wave signal) has to be multiplied by 256 inside the device using a special PLL (to about 11.2 MHz). This signal then replaces the one from the quartz crystal. Big disadvantage: because of the high multiplication factor the reconstructed clock will have great deviations called jitter. The jitter of a word clock is much higher as when using a quartz based clock.

The end of these problems should have been the so called Superclock, which uses 256 times the word clock frequency. This equals the internal quartz frequency, so no PLL for multiplying is needed and the clock can be used directly. But reality was different, the Superclock proved to be much more critical than word clock. A square wave signal of 11 MHz distributed to several devices - this simply means to fight with high frequency technology. Reflections, cable quality, capacitive loads - at 44.1 kHz these factors may be ignored, at 11 MHz they are the end of the clock network. Additionally it was found that a PLL not only generates jitter, but also also rejects disturbances. The slow PLL works like a filter for induced and modulated frequencies above several kHz. As the Superclock is used without any filtering such a kind of jitter and noise suppression is missing. In the end Superclock did not become a commonly accepted standard.

The actual end of these problems is offered by the **SteadyClock** technology of the ADI-642. Combining the advantages of modern and fastest digital technology with analog filter techniques, re-gaining a low jitter clock signal of 22 MHz from a slow word clock of 44.1 kHz is no problem anymore. Additionally, jitter on the input signal is highly rejected, so that even in real world usage the re-gained clock signal is of highest quality.

10.3 Cabling and Termination

Word clock signals are usually distributed in the form of a network, split with BNC T-adapters and terminated with resistors. We recommend using off-the-shelf BNC cables to connect all devices, as this type of cable is used for most computer networks. You will find all the necessary components (T-adapters, terminators, cables) in most electronics and/or computer stores. The latter usually carries 50 Ohm components. The 75 Ohm components used for word clock are part of video technology (RG59).

Ideally, the word clock signal is a 5 Volt square wave with the frequency of the sample rate, of which the harmonics go up to far above 500 kHz. To avoid voltage loss and reflections, both the cable itself and the terminating resistor at the end of the chain should have an impedance of 75 Ohm. If the voltage is too low, synchronization will fail. High frequency reflection effects can cause both jitter and sync failure.

Unfortunately there are still many devices on the market, even newer digital mixing consoles, which are supplied with a word clock output that can only be called unsatisfactory. If the output breaks down to 3 Volts when terminating with 75 Ohms, you have to take into account that a device, of which the input only works from 2.8 Volts and above, does not function correctly already after 3 meter cable length. So it is not astonishing that because of the higher voltage, word clock networks are in some cases more stable and reliable if cables are not terminated at all.

Ideally all outputs of word clock delivering devices are designed as low impedance types, but all word clock inputs as high impedance types, in order to not weaken the signal on the chain. But there are also negative examples, when the 75 Ohms are built into the device and cannot be switched off. In this case the network load is often 2×75 Ohms, and the user is forced to buy a special word clock distributor. Note that such a device is generally recommended for larger studios.

The ADI-642's word clock input can be high-impedance or terminated internally, ensuring maximum flexibility. If termination is necessary (e.g. because ADI-642 is the last device in the chain), push the switch at the back (see chapter 10.1).

In case the ADI-642 resides within a chain of devices receiving word clock, plug a T-adapter into its BNC input jack, and the cable supplying the word clock signal to one end of the adapter. Connect the free end to the next device in the chain via a further BNC cable. The last device in the chain should be terminated using another T-adapter and a 75 Ohm resistor (available as short BNC plug). Of course devices with internal termination do not need T-adaptor and terminator plug.



Due to the outstanding SteadyClock technology of the ADI-642, we recommend not to pass the input signal via T-adapter, but to use the ADI-642's word clock output instead. Thanks to SteadyClock, the input signal will both be freed from jitter and - in case of loss or drop out - be held at the last valid frequency.

11. MIDI and RS232

11.1 MIDI Transmission

MADI allows for a transmission of 64 audio channels over long distances with a single line – perfect. But what about MIDI? Be it remote control commands or sequencer data, in practice only a single MADI line will not suffice. Therefore the ADI-642 also has a MIDI I/O port. The data at the MIDI input are being included into the MADI signal invisibly, and can be collected at the MIDI output of another ADI-642, ADI-648 or a HDSP MADI, at the other end of the MADI line.

Technically every single MADI channel includes several additional bits, containing various information (Channel Status). RME use the usually unused *User Bit* of channel 56 (channel 28 in 96k frame mode), to transmit MIDI data invisibly within MADI, ensuring full compatibility.

The block diagram shows the basic MIDI operation. The MIDI input signal is added to the MADI output signal. The MIDI data found in the MADI input signal will be available at the MIDI output. Handling of the MIDI input signal is completely unaffected by the current routing matrix setup, that is the routing of the audio channels.

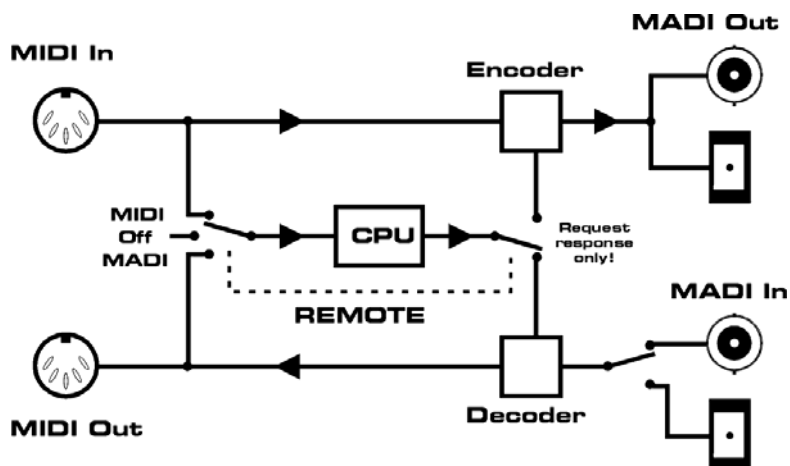

To simplify the serial operation of multiple ADI-642s (see chapter 10.1/10.2), the MIDI signal coming in on the MADI port will be passed on from MADI to MADI when REMOTE is set to MADI (see next page).

This removes the necessity for a MIDI cable connecting MIDI output and MIDI input of the ADI-642, which would realize a direct pass-through of MIDI, from MADI input to MADI output, as well.

11.2 Remote Controlling the ADI-642

The ADI-642 can be completely remote controlled via MIDI. The CPU shown above reacts on specific commands. Furthermore, upon request the CPU will report the complete device status. This includes all controls and LEDs on the front plate. Each ADI-642 can be programmed with its own ID, providing a separated remote control of multiple devices via a single MIDI channel. A description of the MIDI implementation is found in chapter 16.

The button REMOTE is used to select the source of the MIDI remote control commands, and also the destination for the ADI-642's request replies. A push on REMOTE toggles between MIDI port, MADI port and Off. The latter is a safety function to prevent any setup-change by any MIDI signal. In the picture above, the MIDI commands reach the CPU via the MIDI input, and the CPU's feedback on commands is only available at the MIDI output.

To remote control an ADI-642 from a Hammerfall DSP via MADI, REMOTE has to be set to MADI. As can be seen in the block diagram on the next page, this setup provides a complete data path for MIDI in both directions.

11.3 Remote Control Software

A Windows software can be downloaded for free from the RME website. It can use any existing MIDI port within the system to perform remote control and status requests of all ADI-642 via a simple mouse click. Most appealing is the combination with a HDSP MADI (PCI card), offering a direct control of the ADI-642 via MADI. The remote control software then uses a virtual MIDI port of the card (port 3), which directly sends and receives MIDI data via MADI.

The block diagram shows the signal flow in a MADI remote controlled system. MIDI commands from a software on PC or Mac travel via MADI to the MIDI Out and the MADI Out of the ADI-642. At the same time they reach the 642's CPU.

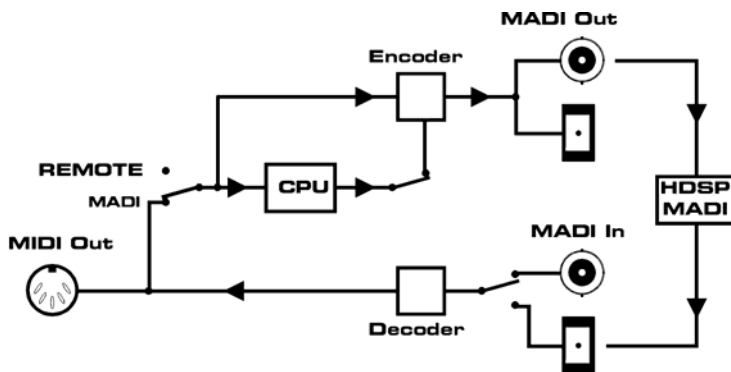

In this configuration, there is no input available for MIDI signals of external devices.

Software download: <http://www.rme-audio.com/download/midiremote.zip>

Brief description of Windows Software ADI-642 MIDI Remote

The program includes an extensive english online help (F1). After the start first choose the function **ADI-642 Front View** in the menu **Functions** (also available via F4). Then select a MIDI input and output via **Options - MIDI I/O Setup**.

Using the command **Options - Connect MIDI Ports** the communication with the ADI-642 is started. The title bar of the program window shows the current state, like selected ID, online / no response / offline.

Save Workspace as allows to store complete setups including all windows in a file, and to reload them at any time.

Send Single Set of Data allows an offline configuration of the ADI-642, and uses a single one-time transmission of all settings.

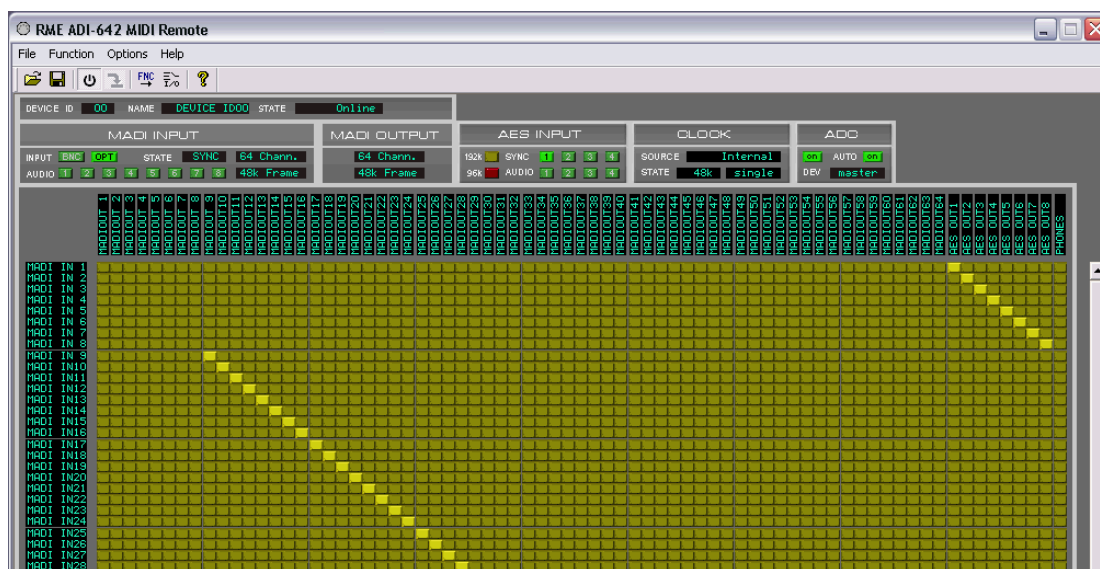

Options – Select Device

Opens a dialog box to select a device ID. Choosing 'All', the current device ID of the unit is ignored. The setting 'All' is not allowed when using more than one ADI-642.

Options – Program Device ID

Opens a dialog box to program a device ID into the ADI-642. Note: programming is fast and not confirmed. Attention: Programming requires to connect not more than one ADI-642 via MIDI!

Via MIDI remote control, all front panel controls of the ADI-642 can be locked (**Lock Keys**). An exception is the REMOTE key. In Off-state Lock Keys is deactivated. Therefore a locking of all the controls can be revoked directly at the unit at any time.

11.4 RS232

Many devices in the professional range of PA and live sound can be remote controlled using serial communication. The most common standard for those is RS232, the interface known from any computer (COM port). Small and cost-efficient converters between RS232 and newer formats, like RS422 or RS485, are widely spread and therefore easily available.

As already described in the chapter about the technology to transmit MIDI via MADI, the ADI-642 also transmits serial data via user bits, in this case on channels 1 to 9. Supported are the Baud rates 9600, 19200, 38400* and 115200. The configuration is done via MIDI, either by sending the according SysEx string, or more comfortably via the Windows software *MIDI Remote*. The specific setting is stored in the unit and doesn't change on reboot.

SysEx Strings

9600 Bd	F0 00 20 0D 62 7F 20 51 00 F7
19200 Bd	F0 00 20 0D 62 7F 20 51 04 F7
38400 Bd	F0 00 20 0D 62 7F 20 51 0C F7*
115200 Bd	F0 00 20 0D 62 7F 20 51 08 F7

* The Baud rate 38400 is supported since firmware 1.4.



To simplify the serial operation of multiple ADI-642s (see chapter 12.2), the serial signal received at the ADC Master's D-sub connector will be passed on by all ADC Slaves, from MADI to MADI.

This removes the necessity for a RS232 split cable, as otherwise the output data would be available at the first unit (the ADC Master), but the return data would have to be fed into the last unit of the chain (the last ADC Slave). By passing on the data, the return data can be fed to the first unit of the chain, and will still reach the ADC Master on the other side of the 'multicore'.

The below diagram explains how ADC controls the signal flow. In normal operation as well as being ADC Master the serial input signal (Rx) is sent to the MADI output, the serial output signal (Tx) comes from the MADI input.

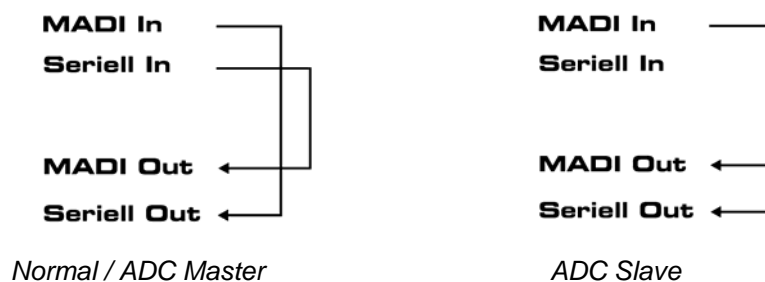

However, at the ADC Slaves the serial input signal is ignored, the data of the MADI input will be sent directly to the MADI output.

12. Application Examples

12.1 Digital AES/EBU Breakout box

As MAD I from/to AES/EBU converter the ADI-642 is an ideal breakout box for RME's HDSP MAD I PCI card. In order to convert the 64 channels of the MAD I card to AES up to eight ADI-642 will be connected in a serial way. But as every ADI-642 causes a MAD I I/O delay of 3 samples, the AES inputs and outputs of different ADI-642s are not sample-aligned, but differently delayed.

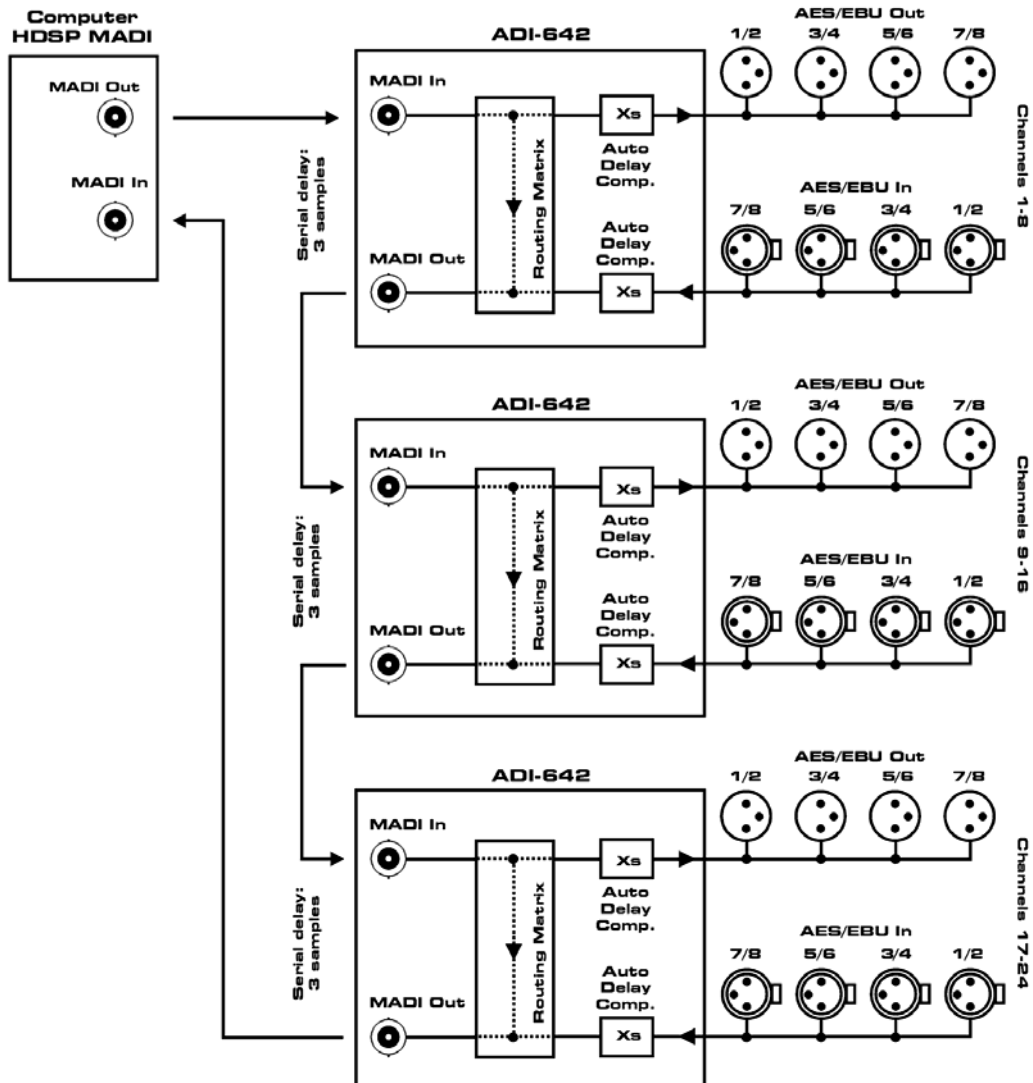

Playing back a test signal on all 64 channels of the MAD I card simultaneously, the signals will be delayed at the outputs of the second ADI-642 by 3 samples, at the third by 6 samples and so on. At Double Speed the delay rises to 6 samples per unit, at Quad Speed to 12 samples.

The problem of the offset between the units is solved by the *Auto Delay Compensation* mode, ADC. After activation in the first unit, all following units configure themselves automatically and delay the AES inputs and outputs in a way that they are fully sample-aligned again.

The application breakout box/computer unveils another delay, the so called *offset* between playback and recording. If a signal is played back from the MAD1 PCI, and recorded again via MAD1 by performing an AES loopback, the record track will show a specific delay against the playback track. The reason for this is that the HDSP MAD1 does signal its own offset to the application, but not the ones of externally connected devices – which it can't know anyway.

The following table lists the offset with deactivated and activated *Auto Delay Compensation*. The values listed here can be entered manually into many programs, thus giving sample-synchronous simultaneous record/playback functionality. At Double Speed and Quad Speed the values rise. Please note that in Double Speed no more than four, in Quad Speed no more than two ADI-642 can be used.

Unit	Breakoutbox	Bob DS	Bob QS
1	7 28	13 31	24 36
2	10 31	19 37	36 48
3	13 34	25 43	-
4	16 37	31 49	-
5	19 40	-	-
6	22 43	-	-
7	25 46	-	-
8	28 49	-	-

7 samples at 48 kHz equal 146 μ s,
49 samples 1 ms.

24 samples at 192 kHz equal 125 μ s,
48 samples 250 μ s.

It is important to understand that ADC corrects only the offset of the AES I/Os between the ADI-642s, but not the total pass-through delay (which is physically impossible). ADC always starts from the worst case, the usage of eight units, and delays the I/Os differently. As shown in the table, ADC increases the offset in the computer by 21 samples at Single Speed, 18 samples at Double Speed, and 12 samples at Quad Speed. The overall slightly increased delay is outweighed by the big advantage of sample-aligned I/Os when using multiple units. So when using only one ADI-642 ADC should stay de-activated.

12.2 Digital AES/EBU Multicore

The ADI-642 is perfectly suited to build up a digital AES/EBU multicore. Depending on the number of used units, from 8 up to 64 channels can be realized, transmitted via MAD1 optical cable lossless and undisturbed to places in a distance of up to 2.000 meters.

On the next page a 24-channel multicore with three ADI-642 per side is shown. The diagram makes clear that ADC is not necessary with a symmetrical setup, i.e ADI-642 at both ends of the multicores, because the delays are built up in a way that all AES/EBU I/Os stay sample-aligned. The amount of the total delay from AES to AES depends on the number of used ADI-642s.

In case ADC is activated in this application, for example to be able to use the Auto Channel Assignment, ADC increases the total delay by 21 samples at Single Speed, 18 samples at Double Speed, and 12 samples at Quad Speed.

Units per side	32 - 48 kHz	64 - 96 kHz	128 - 192 kHz
1	8 29	14 32	24 36
2	12 33	20 38	36 48
3	15 36	26 44	-
4	18 39	32 50	-
5	21 42	-	-
6	24 45	-	-
7	27 48	-	-
8	30 51	-	-

8 samples at 48 kHz equal 166 μ s,
51 samples 1 ms.

24 samples at 192 kHz equal 125 μ s,
48 samples 250 μ s.

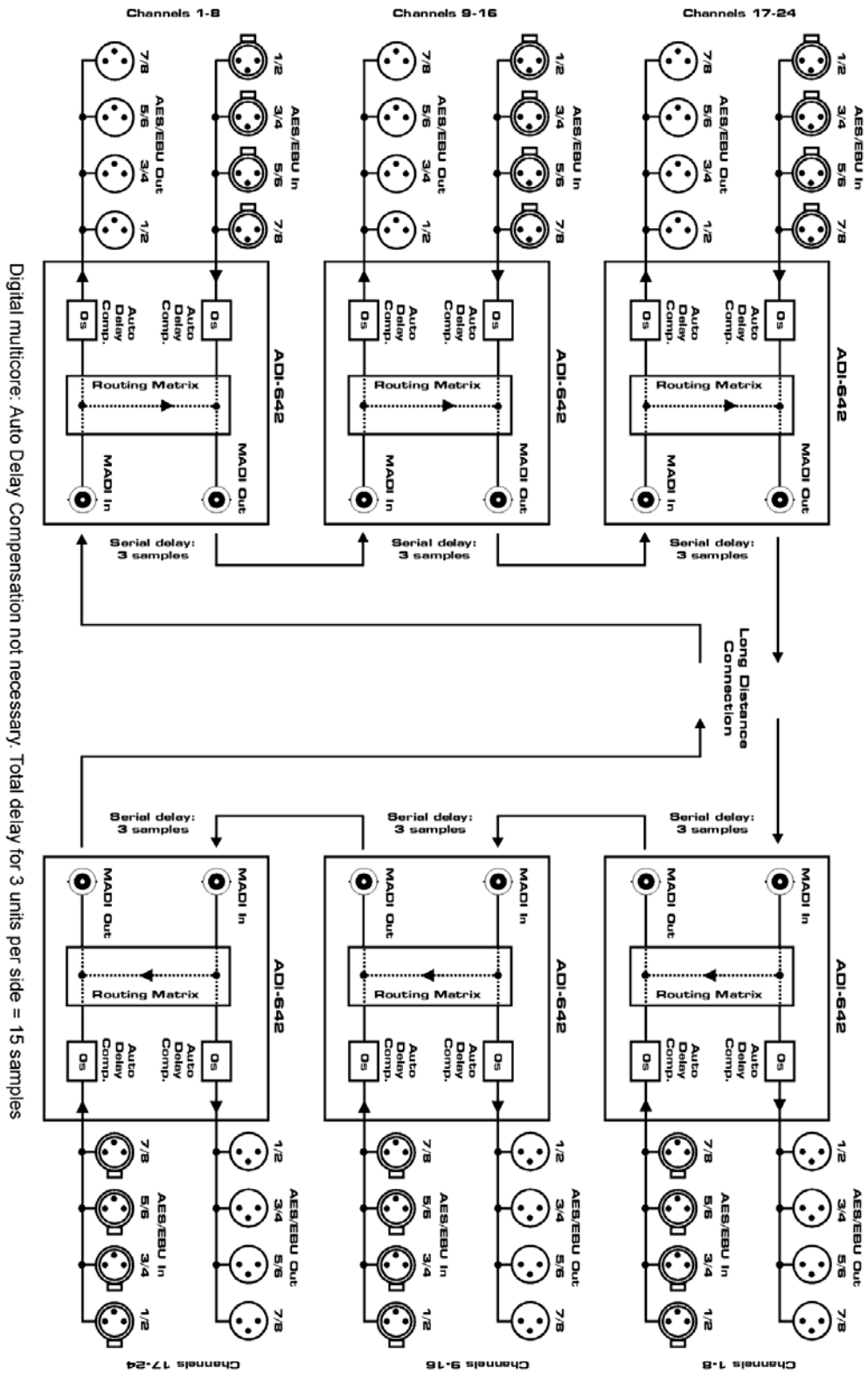

12.3 MADI to MADI Converter

MADI has been used for quite some time now and therefore not all interfaces from different manufacturers are compatible with each other. An AMS Neve Logic DFC e. g. only accepts the 56 channel input format and when a 64 channel signal is applied, the whole input is muted. There exist lots of other but similar examples.

The ADI-642 can serve here as a perfect link, because its MADI input can read any input format. The ADI-642's MADI output can be set to 56 channel or 64 channel output mode (see chapter 7.2). After selecting 96K FRAME there are also 28 or 32 channels in a 96k frame mode. With this option, the ADI-642 can translate a double wire MADI signal (2 single speed channels contain one double speed channel's data) into a single wire double speed signal (1 channel contains 1 channel's data at double sample rate), or vice-versa.

Thanks to an integrated matrix router, no further cabling has to be arranged for, since all MADI input signals can be sent to the MADI output directly via the router.

In short: the ADI-642 makes all MADI interfaces existing at the moment compatible to each other in the easiest way.

12.4 AES Patchbay and Splitter

The integrated Matrix Router makes the ADI-642 also an interesting 4-port AES patchbay. No matter if different devices are to be connected with each other, or one AES signal has to be sent to multiple AES receivers, the ADI-642 can achieve this by simply pushing a button.

12.5 MADI Coaxial / Optical Converter

The integrated Matrix Router allows to send the MADI signals from the MADI input directly to the MADI output. As the ADI-642 supports both coaxial and optical format, it can be used as either coaxial to optical or optical to coaxial format converter. Thanks to a completely newly generated signal, jitter suppression by SteadyClock, and a reclocking of the MADI output signal, the ADI-642 truly represents a hi-end format converter.

For such a simple application, the ADI-642 seems to be highly over-qualified. But seeing the very high prices (but not better quality) of dedicated format converters, we could not resist to add an explicite note on this ADI-642's capability.

12.6 MADI Merger

Another very interesting application, else only possible by using very special and expensive devices, becomes reality when using more than one ADI-642: combining the audio channels of multiple MADI sources into one single MADI wire. The need for this application arises quite often, because many devices don't make use of the full channel count. Often only 32 or 40 channels are used. A HDSP MADI card allows to record 64 channels simultaneously into a computer. To also use the remaining channels, further channels have to be added to the original MADI signal. Two examples will show how the ADI-642 can handle this task with ease.

Example 1: A mixing desk sends 48 channels via MADI. 8 more channels from a RME OctaMic-D (8-channel microphone preamp with AES output) shall be recorded by a HDSP MADI into a computer. This application requires one ADI-642, which has to be inserted into the MADI line. The Routing Matrix is used to loop channels 1 to 48 from MADI input to MADI output. The OctaMic-D will be connected to the four AES inputs. The Routing Matrix is now set up to send the AES input channels to channels 49 to 56 of the MADI output. Now the ADI-642's MADI output signal includes both the original MADI input channels 1 to 48, and the audio signals of the OctaMic (on channels 49 to 56).

Example 2: The signals of two MADI devices shall be united to a single MADI stream. This can be handy, because it requires only one MADI cable for transmission. It can also be a requirement, because the receiving device may have only one input.

The number of ADI-642s necessary is identical to the number of MADI signal sources, so it's two for this example. The first ADI-642 serves as MADI to AES converter. Its AES outputs are connected with the AES inputs of the second ADI-642. The second ADI-642 is used as described in example 1, sending the MADI input signal directly to the MADI output. At the same time, the unit fills the unused MADI channels at its MADI output with the audio signals from the AES inputs.

The diagram to the right shows cabling and signal flow of such an application.

This application example can be realized more efficiently with the RME ADI-648, as this unit converts the MADI signal into 64 ADAT channels. Therefore merging can be done not only with eight channels, but also with lots more. On the other hand, the ADI-642 shines with its single channel matrix, which allows to even insert single channels into the MADI stream.

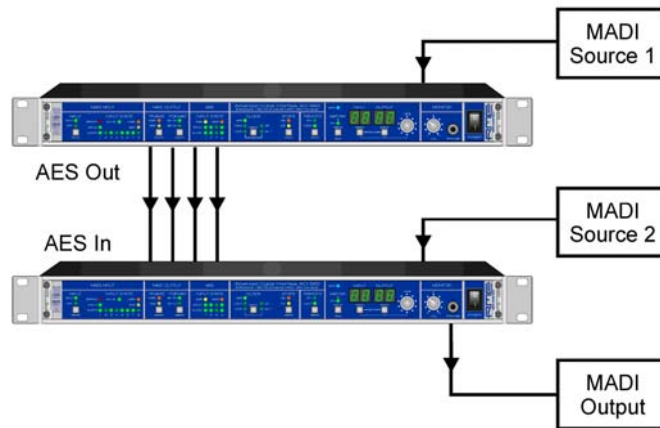

12.7 MADI-net

MADI is much more flexible and powerful as commonly known. To better make clear what MADI really is – a kind of audio network – we introduced the term **MADI-net**. The main point to know is that the MADI input signal is completely rebuilt before it is sent to the MADI output. A clock with active jitter suppression (like SteadyClock) provided, numerous ADI-642 can be daisy chained. The input signal can be passed on in different ways using the matrix router. And when build as as ring loop, audio can even be sent back from all ADI-642 to the first device. The specified length of BNC cable connections is multiplied by the number of used ADI-642, as each device resends the MADI signal as a newly generated original.

A real world example: Imagine a theme park, where different audio is needed at 20 places far away from each other. The audio material is send from a computer, playing back 20 different stereo tracks via a HDSP MADI. The card is connected via BNC to the first ADI-642. This one (like all others) is set up to pass all incoming audio 1:1 to its MADI output, so that the audio is sent directly to the next ADI-642. At the same time the audio is available at each unit using the AES outputs. The distance between the units is more than 50 meters. The last ADI-642 is connected with the HDSP MADI again, as each ADI-642 can also be used to insert signals into the loop (for example surveillance microphones). MIDI transmission also included. Fascinating...

User's Guide



ADI-642

▶ **Technical Reference**

13. Technical Specifications

13.1 Inputs

MADI

- Coaxial via BNC, 75 Ohm, according to AES10-1991
- High-sensitivity input stage (< 0.2 Vpp)
- Optical via FDDI duplex SC connector
- 62.5/125 and 50/125 compatible
- Accepts 56 channel and 64 channel mode, and 96k frame
- Single Wire: up to 64 channels 24 bit 48 kHz
- Double Wire: up to 32 channels 24 bit 96 kHz
- Lock range: 28 kHz – 54 kHz
- Jitter when synced to input signal: < 1 ns
- Jitter suppression: > 30 dB (2.4 kHz)

AES/EBU

- 4 x XLR, transformer balanced, ground-free, according to AES3-1992
- High-sensitivity input stage (< 0.3 Vpp)
- SPDIF compatible (IEC 60958)
- Accepts Consumer and Professional format, copy protection will be ignored
- Single Wire: 4 x 2 channels 24 bit, up to 192 kHz
- Lock range: 28 kHz - 104 kHz, 162 kHz - 204 kHz
- Jitter when synced to input signal: < 1 ns
- Jitter suppression: > 30 dB (2.4 kHz)

Word Clock

- BNC, not terminated (10 kOhm)
- Switch for internal termination 75 Ohm
- Automatic Double/Quad Speed detection and internal conversion to Single Speed
- SteadyClock guarantees super low jitter synchronization even in varispeed operation
- Transformer coupled, galvanically isolated input
- Not affected by DC-offsets within the network
- Signal Adaptation Circuit: signal refresh by auto-center and hysteresis
- Overvoltage protection
- Level range: 1.0 Vpp – 5.6 Vpp
- Lock range: 28 kHz – 220 kHz
- Jitter when synced to input signal: < 1 ns
- Jitter suppression: > 30 dB (2.4 kHz)

13.2 Outputs

MADI

- Coaxial via BNC, 75 Ohm, according to AES10-1991
- Output voltage 600 mVpp
- Cable length coaxial: up to 100 m
- Optical via FDDI duplex SC connector
- 62.5/125 and 50/125 compatible
- Cable length optical: more than 500 m
- Generates 56 channel and 64 channel mode, and 96k frame
- Single Wire: up to 64 channels 24 bit 48 kHz
- Double Wire / 96k frame: up to 32 channels 24 bit 96 kHz

AES/EBU

- 4 x XLR, transformer balanced, ground-free, according to AES3-1992
- Output voltage Professional 4.5 Vpp
- Format Professional according to AES3-1992 Amendment 4
- Format Consumer (SPDIF) according to IEC 60958
- Single Wire: 4 x 2 channels 24 bit, up to 192 kHz

Word Clock

- BNC
- Max. output voltage: 5 Vpp
- Output voltage @ 75 Ohm: 4.0 Vpp
- Impedance: 10 Ohm
- Frequency range: 28 kHz – 220 kHz

DA - Stereo Monitor Output (Phones)

- Resolution: 24 bit
- Dynamic range (DR): 108 dB, 110 dBA @ 44.1 kHz (unmuted)
- Frequency response @ 44.1 kHz, -0.1 dB: 1 Hz – 20.1 kHz
- Frequency response @ 96 kHz, -0.5 dB: 1 Hz – 43.5 kHz
- Frequency response @ 192 kHz, -1 dB: 1 Hz - 70 kHz
- THD+N: -85 dB, < 0.005 %
- Channel separation: > 100 dB
- Maximum output level @ 0 dBFS: +9 dBu
- Output: 6.3 mm TRS jack, unbalanced (stereo)
- Output impedance: 30 Ohm

13.3 MIDI - RS232

MIDI

- 16 channels MIDI
- 5-pin DIN jacks
- Optocoupled, ground-free input
- Invisible transmission via User bit of channel 56 (48k frame)
- Invisible transmission via User bit of channel 28 (96k frame)

RS-232

- 9-pin D-Sub
- Invisible transmission via User bit of channels 1 to 9

13.4 Digital

- Clocks: Internal, AES/EBU In, MADI In, Word clock In
- Low Jitter Design: < 1 ns in PLL mode, all inputs
- Internal clock: 800 ps Jitter, Random Spread Spectrum
- Jitter suppression of external clocks: > 30 dB (2.4 kHz)
- PLL ensures zero dropout, even at more than 100 ns jitter
- Group delay: typically 3 samples

13.5 General

- Power supply: Internal switching PSU, 100 - 240 V AC, 20 Watt
- Typical power consumption: 6 Watt
- Dimensions including rack ears (WxHxD): 483 x 44 x 242 mm (19" x 1.73" x 9.5")
- Dimensions without rack ears/handles (WxHxD): 436 x 44 x 235 mm (17.2" x 1.73" x 9.3")
- Weight: 2 kg (4.4 lbs)
- Temperature range: +5° up to +50° Celsius (41° F up to 122°F)
- Relative humidity: < 75%, non condensing

13.6 Firmware

The ADI-642's main part has been realized using programmable logic. By re-programming of a little component called Flash-PROM, both function and behaviour of the unit can be changed at any time.

At the time of writing this manual, the unit is shipped with firmware 2.1. The firmware version is displayed after power on for about one second by the SYNC and AUDIO LEDs of the AES INPUT STATE section.

V 1.1: Initial release

V 1.2: ADC slave mode allows to configure the Matrix via the unit's controls.

V 1.4: Baud rate 38400 added. MIDI initialisation reworked.

V 2.1: Follow Clock and Lock Keys added.

13.7 Connector Pinouts

AES/EBU

The XLR connectors are wired according to AES3-1992:

- 1 = GND (shield)
- 2 = Signal
- 3 = Signal

AES/EBU and SPDIF are biphas modulated signals, therefore polarity doesn't matter. Pins 2 and 3 are neither hot nor cold, they carry the same signal. But as AES3 uses a balanced transmission they are inverted in polarity.

RS-232

The 9-pin D-Sub Connector is wired according to industry standard:

Signal	In (Rx)	Out (Tx)	GND	NC
Sub-D	2	3	5	9

Internally connected are pins 1 with 6 and 4, and pin 7 with 8.

13.8 MADi User Bit Chart

- RS-232: channels 1 to 9
- ADC: channel 19
- MIDI: channel 56 (48k) / 28 (96k)

14. Technical Background

14.1 Terminology

Single Speed

Sample rate range originally used in Digital Audio. Typical applications are 32 kHz (digital radio broadcast), 44.1 kHz (CD), and 48 kHz (DAT).

Double Speed

Doubles the original sample rate range, in order to achieve higher audio quality and improved audio processing. 64 kHz is practically never used, 88.2 kHz is quite rare in spite of certain advantages. 96 kHz is a common format. Sometimes called **Double Fast**.

Quad Speed

Controversially discussed way of ensuring hi-end audio quality and processing by quadrupling the sample frequency. 128 kHz is non-existent, 176.4 kHz is rare, if at all then 192 kHz is used, e.g. for DVD Audio.

Single Wire

Standard audio data transfer, where the audio signal's sample rate is equal to the rate of the digital signal. Used from 32 to 192 kHz. Sometimes called **Single Wide**.

Double Wire

Before 1998 there were no receiver/transmitter circuits available that could receive or transmit more than 48 kHz. Higher sample rates were transferred by splitting odd and even bits across the L/R channels of a single AES connection. This provides for twice the data rate, and hence twice the sample rate. A stereo signal subsequently requires two AES/EBU ports.

The Double Wire method is an industry standard today, however it has a number of different names, like **Dual AES**, **Double Wide**, **Dual Line** and **Wide Wire**. The AES3 specification uses the uncommon term *Single channel double sampling frequency mode*. When used with the ADAT format, the term S/MUX is commonly used.

Double Wire not only works with Single Speed signals, but also with Double Speed. As an example, Pro Tools HD, whose AES receiver/transmitter only work up to 96 kHz, uses Double Wire to transmit 192 kHz. Four channels of 96 kHz turn into two channels of 192 kHz.

Quad Wire

Similar to Double Wire, with samples of one channel spread across four channels. This way single speed devices can transmit up to 192 kHz, but need two AES/EBU ports to transmit one channel. Also called **Quad AES**.

S/MUX

Since the ADAT hardware interface is limited to Single Speed, the Double Wire method is used for sample rates up to 96 kHz, but usually referred to as S/MUX (Sample Multiplexing). An ADAT port supports four channels this way.

S/MUX4

The Quad Wire method allows to transmit two channels at up to 192 kHz via ADAT. The method is referred to as S/MUX4.

Note: All conversions of the described methods are lossless. The existing samples are just spread or re-united between the channels.

14.2 Lock, SyncCheck and SyncAlign

Digital signals consist of a carrier and the data. If a digital signal is applied to an input, the receiver has to synchronize to the carrier clock in order to read the data correctly. To achieve this, the receiver uses a PLL (Phase Locked Loop). As soon as the receiver meets the exact frequency of the incoming signal, it is locked. This **Lock** state remains even with small changes of the frequency, because the PLL tracks the receiver's frequency.

If an AES signal is applied to the ADI-642, the corresponding SYNC LED starts flashing. The unit indicates LOCK, i. e. a valid input signal (in case the signal is also in sync, the LED is constantly lit, see below).

Unfortunately, LOCK does not necessarily mean that the received signal is correct with respect to the clock which processes the read out of the embedded data. Example [1]: The ADI-642 is set to 44.1 kHz internal clock, and a CD-Player is connected to input AES1. The corresponding LED will start flashing immediately, but the CD-Player's sample rate is generated internally, and thus slightly higher or lower than the ADI-642's internal sample rate. Result: When reading out the data, there will frequently be read errors that cause clicks and drop outs.

Also when using multiple inputs, a simple LOCK is not sufficient. The above described problem can be solved elegantly by setting the ADI-642 from internal clock to AES (its internal clock will then be the clock delivered by the CD-Player). But in case a DAT recorder is connected as a second source, there will again be a slight difference in the sample rate, and therefore clicks and drop outs [2].

In order to display those problems optically at the device, the ADI-642 includes **SyncCheck**[®]. It checks all clocks used for *synchronicity*. If they are not synchronous to each other (i. e. absolutely identical), the SYNC LED of the asynchronous input flashes. In example 1 it would have been obvious that the SYNC AES1 LED kept on flashing after connecting the CD-Player. In example 2, SYNC AES1 would be constantly lit, but the SYNC LED of the input used by the DAT would be flashing.

In practice, SyncCheck allows for a quick overview of the correct configuration of all digital devices. This way one of the most difficult and error-prone topics of the digital studio world finally becomes easy to handle.

A special problem occurs with devices offering several AES or SPDIF inputs. While with MADI all 64 channels share the same clock base, with AES there are several completely independent receivers with their own PLLs and data buffers. Therefore a random error of ± 1 sample difference between the stereo pairs can occur. The ADI-642's exclusive **SyncAlign**[®] technology avoids this effect and guarantees sample synchronicity among all four stereo channels.

14.3 AES/EBU - SPDIF

The most important electrical properties of 'AES' and 'SPDIF' can be seen in the table below. AES/EBU is the professional balanced connection using XLR plugs. The standard is being set by the *Audio Engineering Society* based on the AES3-1992. For the 'home user', SONY and Philips have omitted the balanced connection and use either Phono plugs or optical cables (TOSLINK). The format called S/P-DIF (SONY/Philips Digital Interface) is described by IEC 60958.

Type	AES3-1992	IEC 60958
Connection	XLR	RCA / Optical
Mode	Balanced	Unbalanced
Impedance	110 Ohm	75 Ohm
Level	0.2 V up to 5 Vpp	0.2 V up to 0.5 Vpp
Clock accuracy	not specified	I: ± 50 ppm II: 0.1% III: Variable Pitch
Jitter	< 0.025 UI (4.4 ns @ 44.1 kHz)	not specified

Besides the electrical differences, both formats also have a slightly different setup. The two formats are compatible in principle, because the audio information is stored in the same place in the data stream. However, there are blocks of additional information, which are different for both standards. In the table, the meaning of the first byte (#0) is shown for both formats. The first bit already determines whether the following bits should be read as Professional or Consumer information.

Byte	Mode	Bit 0	1	2	3	4	5	6	7
0	Pro	P/C	Audio?	Emphasis			Locked	Sample Freq.	
0	Con	P/C	Audio?	Copy	Emphasis			Mode	

It becomes obvious that the meaning of the following bits differs quite substantially between the two formats. If a device like a common DAT recorder only has an SPDIF input, it usually understands only this format. In most cases, it will switch off when being fed Professional-coded data. The table shows that a Professional-coded signal would lead to malfunctions for copy prohibition and emphasis, if being read as Consumer-coded data.

Nowadays many devices with SPDIF input can handle Professional subcode. Devices with AES3 input almost always accept Consumer SPDIF (passive cable adapter required).

14.4 MADl Basics

MADl, the serial **M**ultichannel **A**udio **D**igital **I**nterface, has been defined already in 1989 as an extension of the existing AES3 standard following several manufacturers' wish. The format also known as AES/EBU, a balanced bi-phase signal, is limited to two channels. Simply put, MADl contains 28 of those AES/EBU signals in serial, i. e. after one another, and the sample rate can still even vary by +/-12.5%. The limit which cannot be exceeded is a data rate of 100Mbit/s.

Because an exact sampling frequency is used in most cases, the 64 channel mode was introduced officially in 2001. It allows for a maximum sample rate of 48 kHz + ca. 1%, corresponding to 32 channels at 96 kHz, without exceeding the maximum data rate of 100 Mbit/s. The effective data rate of the port is 125 Mbit/s due to additional coding.

Older devices understand and generate only the 56 channel format. Newer devices often work in the 64 channel format, but offer still no more than 56 audio channels. The rest is being eaten up by control commands for mixer settings etc.. The ADI-642 shows that this can be done in a much better way, with an invisible transmission of 16 MIDI channels plus serial RS232 data stream, and the 64-channel MADl signal still being 100% compatible.

For the transmission of the MADl signal, proved methods known from network technology were applied. Most people know unbalanced (coaxial) cables with 75 Ohms BNC plugs, they are not expensive and easy to get. The optical interface is much more interesting due to its complete galvanic separation, but for many users it is a mystery, because very few have ever dealt with huge cabinets full of professional network technology. Therefore here are some explanations regarding 'MADl optical'.

- The cables used are standard in computer network technology. They are thus not at all expensive, but unfortunately not available in every computer store.
- The cables have an internal fibre of only 50 or 62.5 µm diameter and a coating of 125 µm. They are called network cables 62.5/125 or 50/125, the former mostly being blue and the latter mostly being orange. Although in many cases not clearly labeled, these are always (!) glass fibre cables. Plastic fibre cables (POF, plastic optical fibre) can not be manufactured in such small diameters.
- The plugs used are also an industry standard and called SC. Please don't mix them up with ST connectors, which look similar to BNC connectors and are being screwed. Plugs used in the past (MIC/R) were unnecessarily big and are not being used any longer.
- The cables are available as a duplex variant (2 cables being glued together) or as a simplex variant (1 cable). The ADI-642's opto module supports both variants.
- The transmission uses the multimode technique which supports cable lengths of up to almost 2 km. Single mode allows for much longer distances, but it uses a completely different fibre (8 µm). By the way, due to the wave-length of the light being used (1300 nm), the optical signal is invisible to the human eye.

14.5 SteadyClock

The SteadyClock technology of the ADI-642 guarantees an excellent performance in all clock modes. Its highly efficient jitter suppression refreshes and cleans up any clock signal, and provides it as reference clock at the word clock output.

Usually a clock section consists of an analog PLL for external synchronization and several quartz oscillators for internal synchronisation. SteadyClock requires only one quartz, using a frequency not equalling digital audio. Latest circuit designs like hi-speed digital synthesizer, digital PLL, 100 MHz sample rate and analog filtering allow RME to realize a completely newly developed clock technology, right within the FPGA at lowest costs. The clock's performance exceeds even professional expectations. Despite its remarkable features, SteadyClock reacts quite fast compared to other techniques. It locks in fractions of a second to the input signal, follows even extreme varipitch changes with phase accuracy, and locks directly within a range of 28 kHz up to 200 kHz.

SteadyClock has originally been developed to gain a stable and clean clock from the heavily jittery MADi data signal. The embedded MADi clock suffers from about 80 ns jitter, caused by the time resolution of 125 MHz within the format. Common jitter values for other devices are 5 ns, while a very good clock will have less than 2 ns.

The picture to the right shows the MADi input signal with 80 ns of jitter (top graph, yellow). Thanks to SteadyClock this signal turns into a clock with less than 2 ns jitter (lower graph, blue).

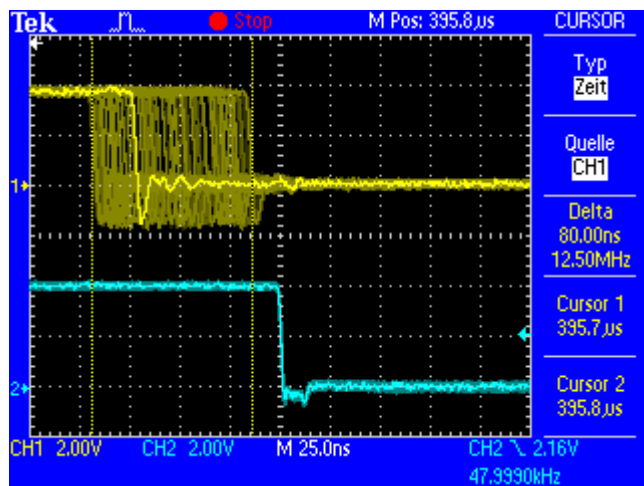

Using the other input sources of the ADI-642, word clock and AES/EBU, you'll most probably never experience such high jitter values. But SteadyClock is not only ready for them, it would handle them just on the fly.

The screenshot to the right shows an extremely jittery word clock signal of about 50 ns jitter (top graph, yellow). Again SteadyClock provides an extreme clean-up. The filtered clock shows less than 2 ns jitter (lower graph, blue).

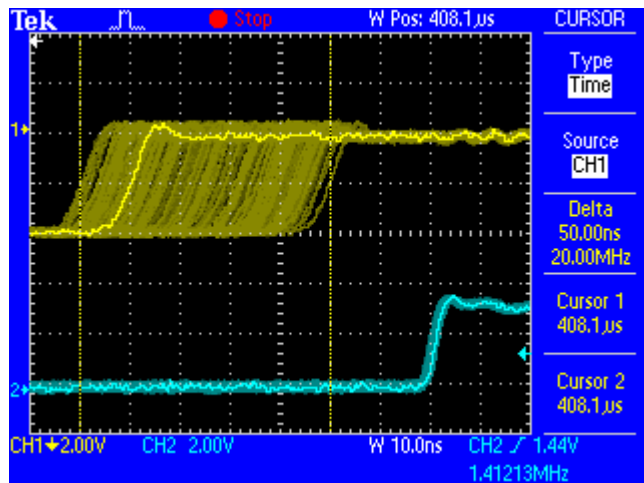

The cleaned and jitter-free signal can be used as reference clock for any application, without any problem. The signal processed by SteadyClock is of course not only used internally, but also available at the ADI-642's word clock output. It is also used to clock the digital outputs MADi and AES/EBU.

15. Block Diagram

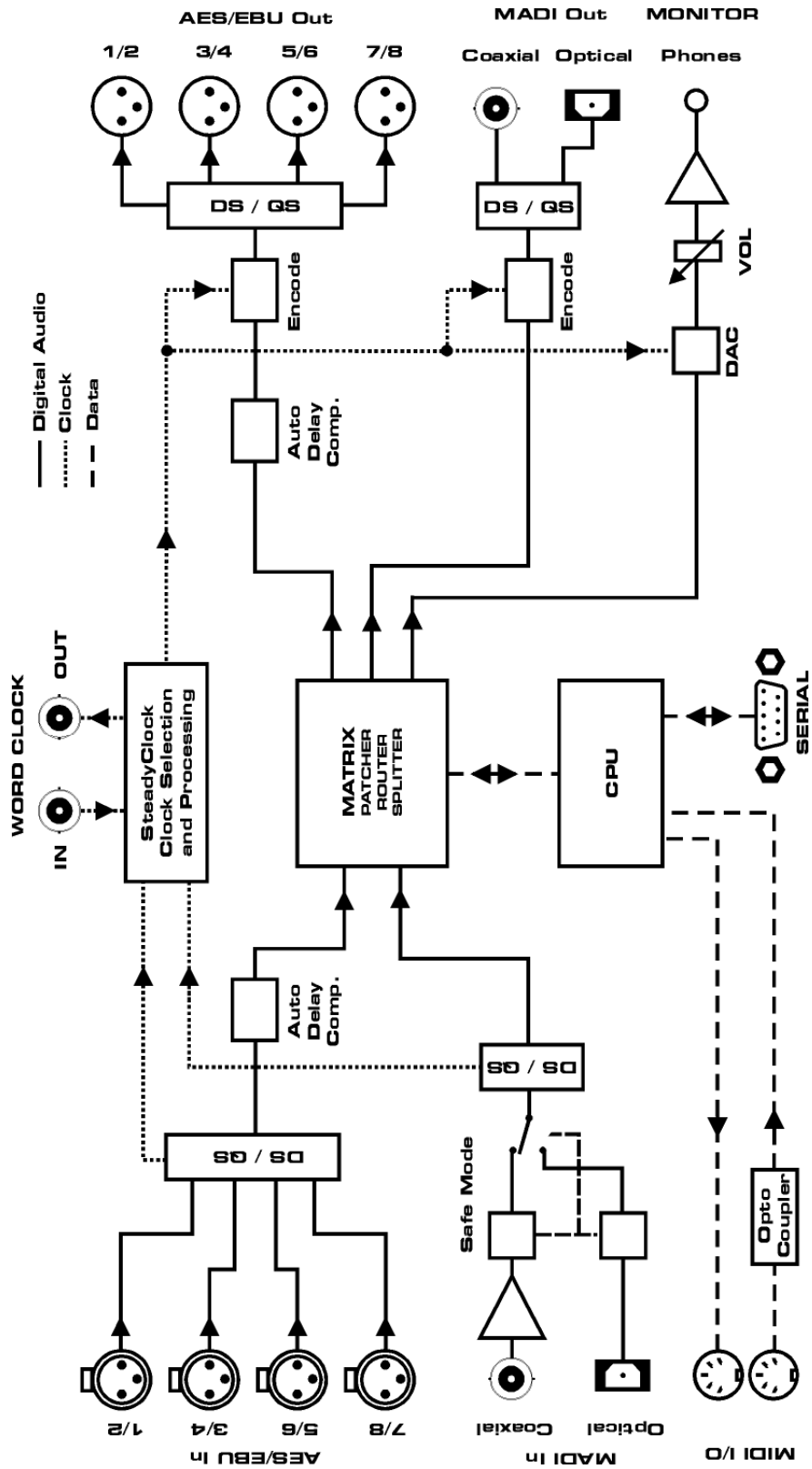

16. MIDI Implementation Chart ADI-642

16.1 Basic SysEx Format

<u>Value</u>	<u>Name</u>
F0h	SysEx header
00h 20h 0Dh	MIDITEMP manufacturer ID
62h	Model ID (ADI-642)
00h..7Eh, 7Fh	Device ID. 7Fh = broadcast (all IDs)
mm	Message type
nn	Parameter number (see table 1)
oo	Databyte
F7h	EOX

16.2 Message Types

<u>Value</u>	<u>Name</u>
10h	Request value
20h	Set value
30h	Value response

Request Value

Format: F0 00 20 0D 62 (dev ID) 10 F7

This string triggers a complete dump of all value response data bytes.

Value Response

After being triggered by receiving a request value command, device sends a string of all value response data bytes. Message type is set to 30h.

Set Value

Sets any number of parameters.
nn / oo can be repeated freely.

16.3 MADl Input State – Redundancy Mode

The MADl input can be BNC or optical. When the ADI-642 enters Redundancy mode, it uses the other input, although not chosen and signalled by the MADl input select byte. See below table.

MADl Input Select	MADl Input State	Actual input in use
0 = BNC	0 = normal operation	BNC
1 = Optical	0 = normal operation	Optical
0 = BNC	1 = Redundancy mode	Optical
1 = Optical	1 = Redundancy mode	BNC

16.4 Table

No.	No.	Name	Set Value	Value Resp.	Databytes
00h	0	MADI output channel 1	x	x	MADI input channel 1..64: 00h..3Fh, AES input channel 1..8: 40h..47h, mute: 48h
01h	1	MADI output channel 2	x	x	
02h	2		x	x	
03h	3		x	x	(dto.)
04h	4		x	x	(dto.)
05h	5		x	x	(dto.)
06h	6		x	x	(dto.)
07h	7		x	x	(dto.)
08h	8		x	x	(dto.)
09h	9		x	x	(dto.)
0Ah	10		x	x	(dto.)
0Bh	11		x	x	(dto.)
0Ch	12		x	x	(dto.)
0Dh	13		x	x	(dto.)
0Eh	14		x	x	(dto.)
0Fh	15		x	x	(dto.)
10h	16		x	x	(dto.)
11h	17		x	x	(dto.)
12h	18		x	x	(dto.)
13h	19		x	x	(dto.)
14h	20		x	x	(dto.)
15h	21		x	x	(dto.)
16h	22		x	x	(dto.)
17h	23		x	x	(dto.)
18h	24		x	x	(dto.)
19h	25		x	x	(dto.)
1Ah	26		x	x	(dto.)
1Bh	27		x	x	(dto.)
1Ch	28		x	x	(dto.)
1Dh	29		x	x	(dto.)
1Eh	30		x	x	(dto.)
1Fh	31		x	x	(dto.)
20h	32		x	x	(dto.)
21h	33		x	x	(dto.)
22h	34		x	x	(dto.)
23h	35		x	x	(dto.)
24h	36		x	x	(dto.)
25h	37		x	x	(dto.)
26h	38		x	x	(dto.)
27h	39		x	x	(dto.)
28h	40		x	x	(dto.)
29h	41		x	x	(dto.)
2Ah	42		x	x	(dto.)
2Bh	43		x	x	(dto.)
2Ch	44		x	x	(dto.)
2Dh	45		x	x	(dto.)
2Eh	46		x	x	(dto.)
2Fh	47		x	x	(dto.)

30h	48		x	x	(dto.)
31h	49		x	x	(dto.)
32h	50		x	x	(dto.)
33h	51		x	x	(dto.)
34h	52		x	x	(dto.)
35h	53		x	x	(dto.)
36h	54		x	x	(dto.)
37h	55		x	x	(dto.)
38h	56		x	x	(dto.)
39h	57		x	x	(dto.)
3Ah	58		x	x	(dto.)
3Bh	59		x	x	(dto.)
3Ch	60		x	x	(dto.)
3Dh	61		x	x	(dto.)
3Eh	62		x	x	(dto.)
3Fh	63	MADI output channel 64	x	x	(dto.)
40h	64	AES output channel 1	x	x	(dto.)
41h	65		x	x	(dto.)
42h	66		x	x	(dto.)
43h	67		x	x	(dto.)
44h	68		x	x	(dto.)
45h	69		x	x	(dto.)
46h	70		x	x	MADI input channel 1..64: 00h..3Fh,
47h	71	AES output channel 8	x	x	AES input channel 1..8: 40h..47h,
48h	72	phones output (left)	x	x	mute: 48h
49h	73			x	(reserved)
4Ah	74			x	(reserved)
4Bh	75			x	(reserved)
4Ch	76			x	(reserved)
4Dh	77			x	(reserved)
4Eh	78			x	(reserved)
4Fh	79	matrix output display	x	x	00h..48h see above, 49h sets adc auto mode
50h	80	settings byte 1	x	x	hex coded value of byte (see below)
51h	81	settings byte 2	x	x	hex coded value of byte (see below)
52h	82	MADI audio 1..4		x	bit 0..3 = audio 1..4, bit 4..7 = 0
53h	83	MADI audio 5..8		x	bit 0..3 = audio 5..8, bit 4..7 = 0
54h	84	AES audio 1..4		x	bit 0..3 = audio 1..4, bit 4..7
55h	85	info byte 1		x	hex coded value of byte (see below)
56h	86	info byte 2		x	hex coded value of byte (see below)
57h	87	info byte 3		x	hex coded value of byte (see below)
58h	88		x		set device ID (request displays in header)

50h	80	settings byte 1	MSB / 7	0
			6	madi input: 0 = BNC, 1 = opt
			5	0
			4	madi frame: 0 = 48k, 1 = 96k
			3	madi format: 0 = 56ch, 1 = 64ch
			2	MSB / 2
			1	1
			1	clock select: 0 = int 44.1, 1 = int 48, 2 = AES,
			1	clock select: 3 = MADI, 4 = WCK
			LSB / 0	LSB / 0
			LSB / 0	clock select

51h	81	settings byte 2	MSB / 7	0
			6	0
			5	MSB / 1
			4	LSB / 0
			4	clock state: 0 = single speed, 1 = ds, 2 = qs
			3	clock state
			3	MSB / 1
			2	LSB / 0
			2	serial I/O baud rate: 0 = 9600, 1 = 19200
			2	serial I/O baud rate: 2 = 115200 3=38400*
			1	auto slave: 0 = off, 1 = on, request only
			1	adc: 0 = off, 1 = on
			LSB / 0	LSB / 0

55h	85	info byte 1	MSB / 7	0
			6	MADI input override
			5	WCK lock
			4	MADI lock
			3	AES 4 lock
			2	AES 3 lock
			1	AES 2 lock
			1	AES 1 lock
			LSB / 0	LSB / 0

56h	86	info byte 2	MSB / 7	0
			6	MADI input 96k frame
			5	MADI input 64ch
			4	MADI sync
			3	AES 4 sync
			2	AES 3 sync
			1	AES 2 sync
			1	AES 1 sync
			LSB / 0	LSB / 0

57h	87	info byte 3	MSB / 7	0
			6	MSB / 2
			5	1
			4	LSB / 0
			4	adc device no.: 0 = master
			3	adc device no.
			3	MSB / 1
			2	LSB / 0
			2	adc device no.
			2	MIDI remote: 0 = off, 1 = DIN, 2 = MADI
			1	MIDI remote
			1	AES input 192k
			1	AES input 96k
			LSB / 0	LSB / 0

* Since firmware 1.4.