

## User's Guide



## **QuadMic**

Portable Professional Mic Preamp  
4-channel Microphone / Line Preamp with Line Outputs  
Universal Power Input

---

## Contents

<b>1</b>	<b>Introduction</b> .....	<b>3</b>
<b>2</b>	<b>Package Contents</b> .....	<b>3</b>
<b>3</b>	<b>Brief Description and Characteristics</b> .....	<b>3</b>
<b>4</b>	<b>Technical Specifications</b> .....	<b>3</b>
<b>5</b>	<b>Power Supply</b> .....	<b>4</b>
<b>6</b>	<b>Operation and Usage</b>	
6.1	Connections .....	5
6.2	Mic/Line Inputs .....	6
6.3	Line Outputs.....	6
<b>7</b>	<b>Accessories</b> .....	<b>6</b>
<b>8</b>	<b>Warranty</b> .....	<b>7</b>
<b>9</b>	<b>Appendix</b> .....	<b>7</b>
<b>10</b>	<b>Block Diagram QuadMic</b> .....	<b>8</b>
<b>11</b>	<b>CE / FCC Compliance</b> .....	<b>9</b>

---

## 1. Introduction

Thank you for choosing the QuadMic. This unique Mic Preamp allows to connect any kind of microphone to any line level inputs. Thanks to the option of battery-powered operation, the QuadMic makes an ideal companion to the Hammerfall DSP System in mobile recording situations. But excellent signal/noise ratio, sophisticated discrete Class-A technology, and lots of important features make the QuadMic your first choice even for studio use!

## 2. Package Contents

Please check that your QuadMic's package contains each of the following:

- QuadMic
- Quick Info guide
- RME Driver CD
- 12 V car cable
- Battery cable
- Power supply 12 V / 1.25 A and power cord

## 3. Brief Description and Characteristics

- 4 separated microphone inputs with discrete Class-A frontend
- Phantom power 48V, low cut and phase switchable per channel
- 48V, Clip and Level LED per channel
- Gain +10 dB up to +60 dB adjustable per channel
- Reference level switchable HiGain / +4 dBu
- Fully compatible to RME's ADI-8 series and HDSP series
- Servo balanced inputs and outputs
- Wide frequency response with special RF input filters
- Wide operating voltage range
- 100% hum-free via internal switching regulators

## 4. Technical Specifications

- Inputs: XLR or 1/4" TRS (stereo) jack, servo balanced
- Impedance: 2 kOhm
- Signal to Noise ratio (SNR): 129 dB EIN @150 Ohm
- THD: < -107 dB, < 0.00045 %
- THD+N: < -100 dB, < 0.001 %
- Crosstalk: > 110 dB
- Frequency response -0.5 dB: 5 Hz - 200 kHz
- Line Out: 1/4" TRS (stereo) jack, servo balanced
- Maximum output level: +21 dBu
- Output impedance: 47 Ohm
- Output level switchable Hi Gain / +4 dBu

---

## 5. Power Supply

- Current drawn at 12 Volt operating voltage: 380 mA (4.6 Watts)
- Allowed input voltage DC 7 V – 38 V, AC 7 V – 27 V.

In order to make operating the QuadMic as flexible as possible, it contains a switching regulator of the latest technology, which not only has a high efficiency (> 90%), but also prevents internal hum noise, as it operates at 100 kHz. Another advantage: the QuadMic accepts any power supply with a voltage between 7 and 38 V DC, no matter which polarity, and even between 6 and 28 V AC. Given the power supply can deliver the current needed.

The supplied high-quality switching power supply, 12 V / 1.25 A, not only accepts any mains voltage between 100 V and 240 V (usable world-wide), but is also fully regulated against voltage fluctuations. Additionally it only weighs 150 g in spite of its high power of 15 Watts. This power supply can operate up to three QuadMic when used with a special split adapter cable.



The large voltage range of the QuadMic also allows for the use of a rechargeable lead-battery instead of a power supply, for completely independent mobile operation. A matching connection cable (power jack to terminals 6.3 mm, see picture) is part of the supplied contents.



We tested a Panasonic LC-R122R2PG battery, 12 V 2.2 Ah, which can operate the QuadMic for 4 hours. Measuring the voltage while discharging shows that the QuadMic remains completely in working order even shortly before the battery collapses (6 Volts.)

---

## 6. Operation and Usage

### 6.1 Controls

The front of the QuadMic has the gain knobs, switches for low cut, phantom power and phase, and several status LEDs:

**+48V** (LED) lights up when phantom power is active. Phantom power should only be activated when using condenser microphones which require such a power supply.

The **CLIP** LED has been designed to act like the OVR LEDs of the ADI-8 series. It lights up 2 dB before the reference level selected on the back of the unit plus a headroom of 9 dB is reached. At Hi Gain the LED lights up at +17 dBu output level, selecting +4 dBu it lights up at +11 dBu.

**SIG** (Signal) indicates the presence of an input signal. The threshold of -25 dBu is rather high compared to other equipment. With this, SIG also indicates a useful output level, maintained by a correct GAIN adjustment.

**GAIN** allows a stepless and very precise adjustment of the amplification between +10 dB and +60 dB.

**+48V** (switch) activates phantom power. Generating +48 V draws additional current. Therefore phantom power should only be activated when using condenser microphones which require such a power supply, and only on the specific channel.

**LO CUT** activates a hi-pass at 80 Hz, 18 dB per octave. This filter can remove rumble and other low frequency noise.

**PHASE** changes the polarity. Phase cancellations and sound changes can be caused by using multiple microphones at different places, or wrongly soldered cables. In such cases PHASE can eliminate the error by adding an additional phase inversion.

The back of the QuadMic has the 4 analog inputs and outputs, the power supply connector **AUX**, and the choice of reference level.

**MICROPHONE / LINE INPUTS:** 4 Neutrik XLR / TRS combo jacks. Thanks to the servo balanced designs and a high maximum input level (+11 dBu), the inputs can be used balanced or unbalanced, with XLR or TRS jack, with microphone or line levels – nearly everything is possible.

**LINE LEVEL OUTPUTS:** 4 TRS (stereo) jacks. The electronic output stage is built in a servo balanced design which handles monaural (unbalanced) and stereo jacks (balanced) correctly.

**Hi Gain / +4 dBu:** Defines the reference level of the Line Level Outputs. See chapter 6.3, Line Outputs.

**AUX:** Connect power supply, lead-battery or battery. See chapter 5, Power Supply.

---

## 6.2 Mic/Line Inputs

The QuadMic provides 4 balanced Mic and Line inputs via 1/4" TRS (stereo) and XLR jacks. The electronic input stage is built in a servo balanced design which handles monaural and stereo jacks correctly. When used unbalanced it automatically corrects the gain by 6 dB.



*When using unbalanced cables with stereo TRS jacks, the 'ring' contact of the cable's jack should be connected to pin 1 (ground). Otherwise noise may occur, caused by the unconnected negative input of the balanced input.*

The pinout follows international standards. XLR pin 2 + or hot, pin 3 – or cold, pin 1 ground. TRS tip + or hot, ring – or cold.

## 6.3 Line Outputs

The 4 short circuit protected, low impedance and servo balanced line outputs are available as (stereo) 1/4" TRS jacks. The electronic output stage is built in a servo balanced design which handles monaural and stereo jacks correctly. When used unbalanced it automatically corrects the gain by 6 dB.

To maintain an optimum level for devices connected to the analog outputs the QuadMic includes a switch which allows to change the reference level of all 4 outputs simultaneously.

The QuadMic can generate a maximum level of +21 dBu without distortion. However, the CLIP LED has been designed to act like the OVR LEDs of the ADI-8 series. It lights up 2 dB before the reference level selected on the back of the unit, plus a headroom of 9 dB, is reached. At Hi Gain the LED lights up at +17 dBu output level, selecting +4 dBu it lights up at +11 dBu.

This also means that the CLIP LED lights up 4 dB before the QuadMic actually reaches the maximum level. Such an additional headroom is considered to be useful in real world operation.

Selecting +4 dBu changes not only the threshold of the CLIP LED. In fact the output signal is attenuated by 6 dB, so for the same output level the amplification has to be increased via GAIN. With this trick the QuadMic reaches the maximum signal to noise ratio on +4 dBu based inputs (like our ADI-8 series), because microphone preamps have better EIN values at higher amplification. In case of an extreme recording situation, where the gain of the QuadMic is no longer sufficient, selecting Hi Gain will again provide the highest amplification possible.

The pinout follows international standards. TRS tip + or hot, ring – or cold.

## 7. Accessories

Part number	Description
36000	19", 1UH Universal rack holder

This 19" rack holder has holes for QuadMic, Digiface and Multiface. Two units can be installed side by side in any combination. The rack holder also includes holes for nearly all 19" half-rack units from other manufacturers.

37011	Power supply for HDSP CardBus card
-------	------------------------------------

Robust and light weight switching power supply, 100V-240V AC, 12V 1.25 A DC.

---

## 8. Warranty

Each individual QuadMic undergoes comprehensive quality control and a complete test at RME before shipping. The usage of high grade components allow us to offer a full two year warranty. We accept a copy of the sales receipt as valid warranty legitimation.

If you suspect that your product is faulty, please contact your local retailer. The warranty does not cover damage caused by improper installation or maltreatment - replacement or repair in such cases can only be carried out at the owner's expense.

RME does not accept claims for damages of any kind, especially consequential damage. Liability is limited to the value of the QuadMic. The general terms of business drawn up by Synthax Audio AG apply at all times.

## 9. Appendix

RME news, driver updates and further product information are available on our website:

<http://www.rme-audio.com>

If you prefer to read the information off-line, you can load a complete copy of the RME website from the RME Driver CD (in the **rmeaudio.web** directory) into your browser.

## Trademarks

All trademarks, registered or otherwise, are the property of their respective owners. RME is a registered trademark of RME Intelligent Audio Solutions. QuadMic is a trademark of RME Intelligent Audio Solutions.

Copyright © Matthias Carstens, 6/2003. Version 1.0

Although the contents of this User's Guide have been thoroughly checked for errors, RME can not guarantee that it is correct throughout. RME does not accept responsibility for any misleading or incorrect information within this guide. Lending or copying any part of the guide or the RME Driver CD, or any commercial exploitation of these media without express written permission from RME Intelligent Audio Solutions is prohibited. RME reserves the right to change specifications at any time without notice.

## 10. Block Diagram QuadMic

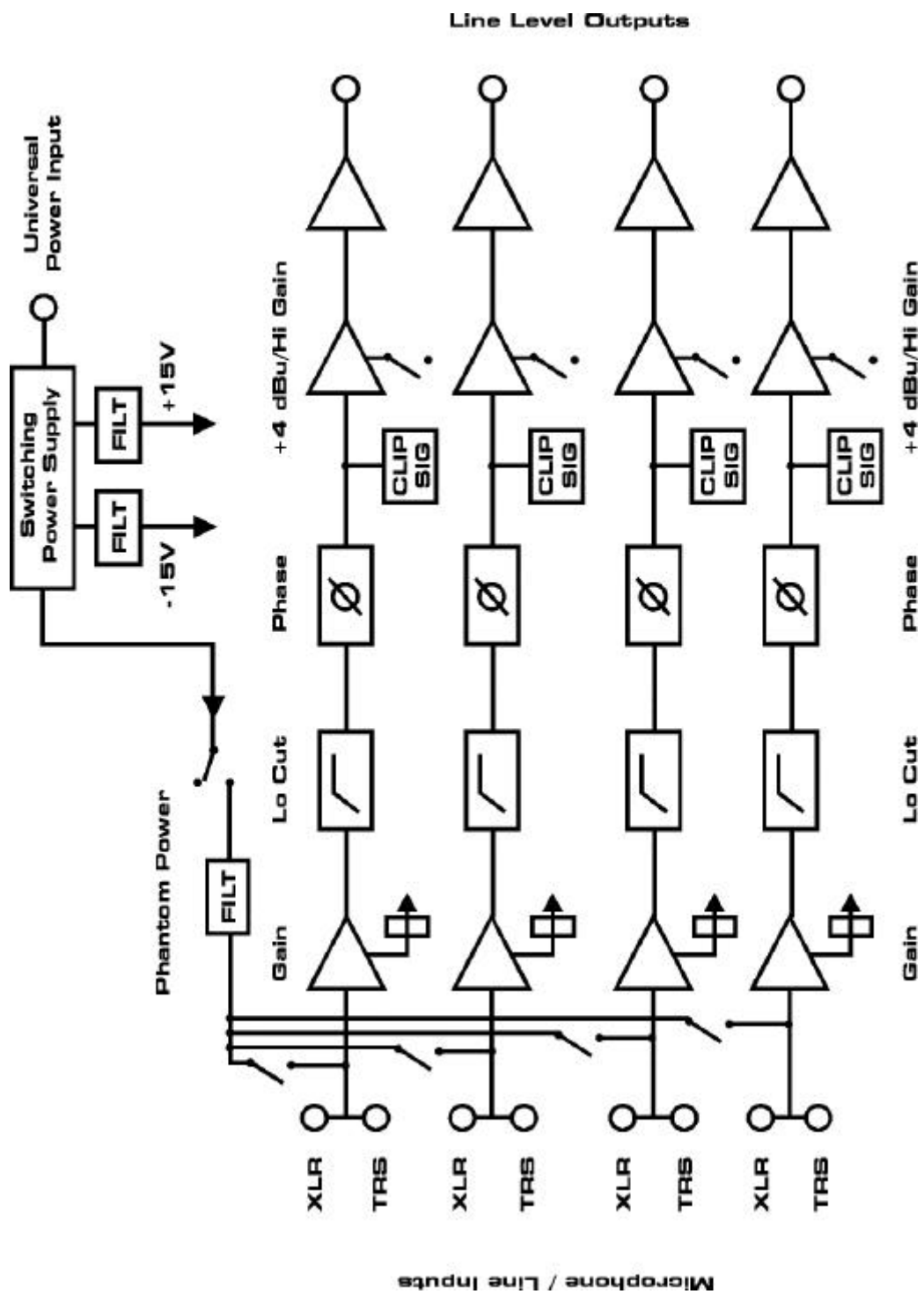

---

## 11. CE / FCC Compliance Statements

### CE

This device has been tested and found to comply with the EN55022 class B and EN50082-1 norms for digital devices, according to the European Council directive on counterpart laws in the member states relating to electromagnetic compatibility (EMVG).

### FCC

This device has been tested and found to comply with the requirements listed in FCC Regulations, part 15 for Class 'B' digital devices. Compliance with these requirements provides a reasonable level of assurance that your use of this product in a residential environment will not result in harmful interference with other electronic devices.

This equipment generates radio frequencies and, if not installed and used according to the instructions in the User's Guide may cause interference harmful to the operation of other electronic devices.

Compliance with FCC regulations does not guarantee that interference will not occur in all installations. If this product is found to be the source of interference, which can be determined by turning the unit off and on again, please try to eliminate the problem by using one of the following measures:

- Relocate either this product or the device that is being affected by the interference
- Use power outlets on different branch circuits, or install AC line filters
- Contact your local retailer or any qualified radio and television engineer

FCC compliance statement: Tested to comply with FCC standards for home or office use.